

# 2014 Mazda CX-5 TURN AND HAZARD WARNING LIGHT

0918-5

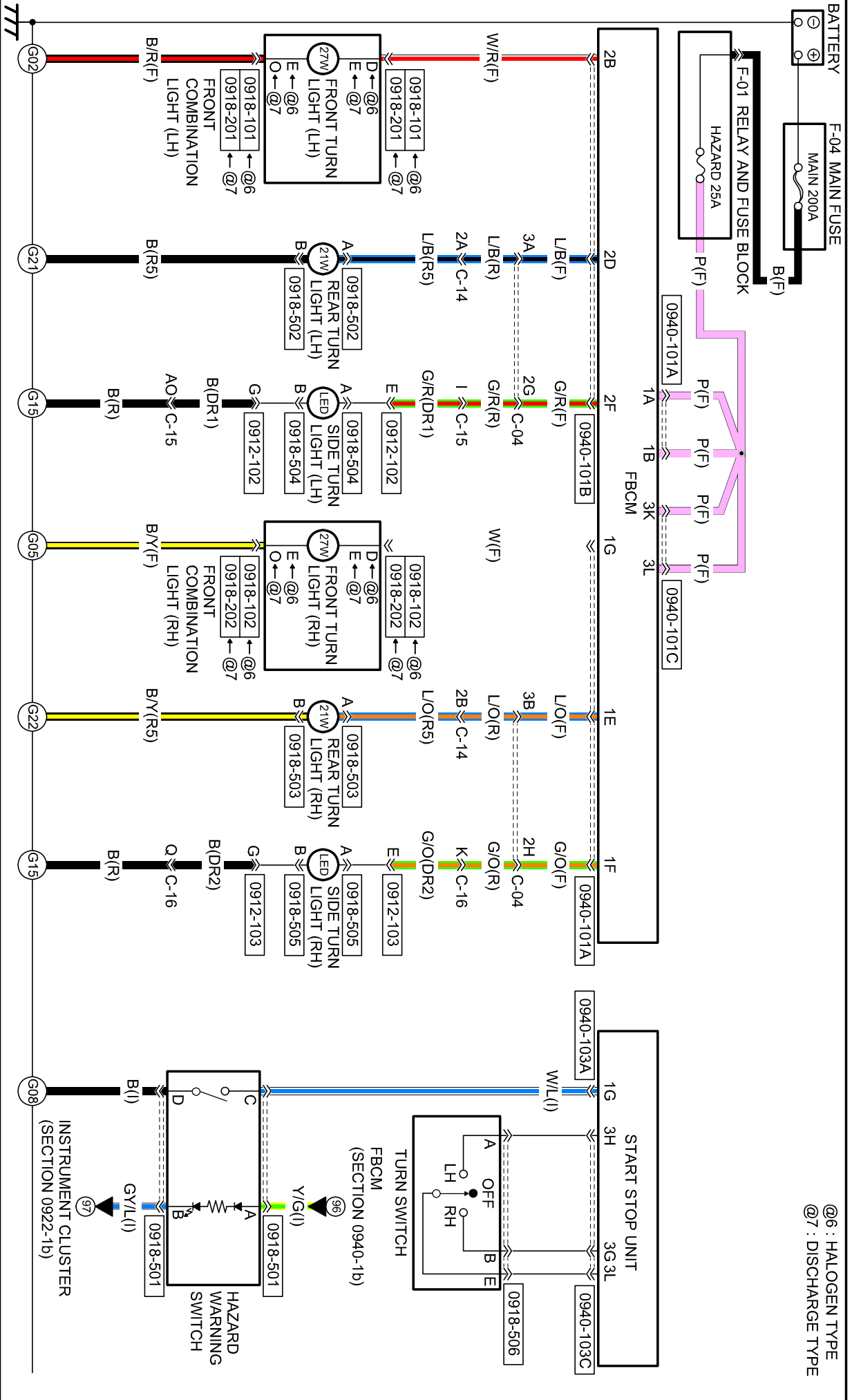

@6 : HALOGEN TYPE  
@7 : DISCHARGE TYPE

# 2014 Mazda CX-5 TURN AND HAZARD WARNING LIGHT

0918-5

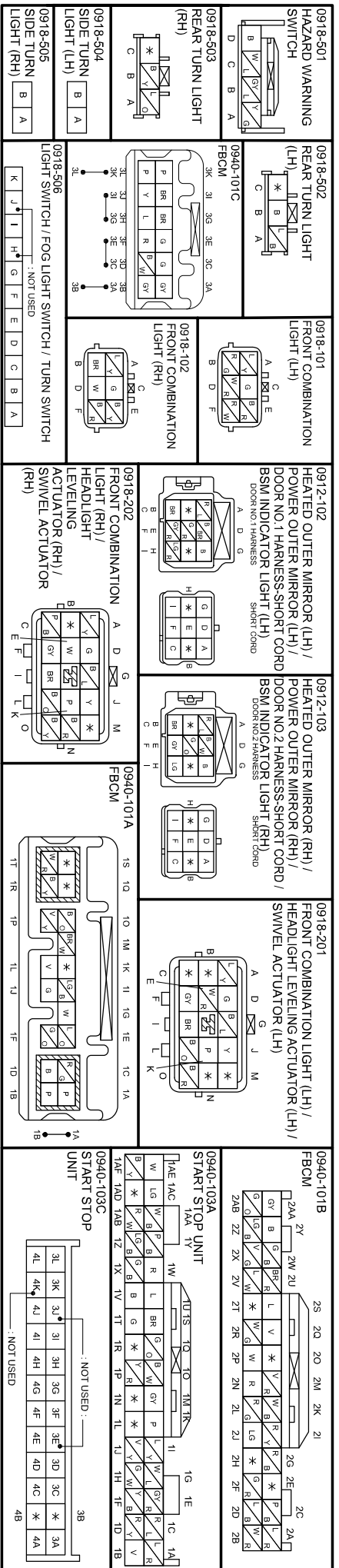

**FBCM terminal voltage table (reference)**

Terminal	Measurement conditions	Voltage (V)
1A	Under any condition	B+
1B	Under any condition	B+
1E	Ignition switched ON (engine off)	1.0 or less ⇄ B+
1F	Ignition switched ON (engine off)	1.0 or less
1G	Ignition switched ON (engine off)	1.0 or less ⇄ B+
2B	Ignition switched ON (engine off)	1.0 or less ⇄ B+
2D	Ignition switched ON (engine off)	1.0 or less
2F	Ignition switched ON (engine off)	1.0 or less ⇄ B+
3K	Under any condition	B+
3L	Under any condition	B+

**Start stop unit terminal voltage table (reference)**

Terminal	Measurement conditions	Voltage (V)
1G	Hazard warning switch not pressed (OFF) Hazard warning switch pressed (ON)	B+ 1.0 or less

