

# MasterSheet

033 0051  
Revision 11/20/09



Complete Car Audio  
Installation Instructions  
**CRUTCHFIELD™**

**2001-  
Mazda  
Protege, Protege 5**



## IMPORTANT



Before starting, compare items on your invoice with items received. Carefully check through packaging material. If any item is missing, please call **Crutchfield Technical Support at 1-800-955-9094**.

Although reasonable attempts are made to verify the accuracy of the information contained in this MasterSheet, it is presented without warranties or guarantees of any type due to the constantly changing nature of this type of information and running changes in vehicle production. Any person or entity using this information does so at his or its own risk. If you find our instructions are different from your vehicle, or if you have questions, do not continue with your installation. Contact our toll-free technical support for assistance.

## Inside...

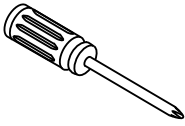
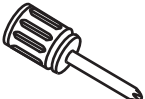
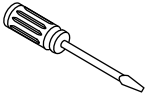
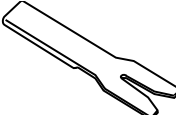

Page

2	Factory Radio Removal			✓		✓
3	Receiver Installation					
4	Front Door Speakers	✓		✓	✓	
5	Front Door Speakers (continued)					
6	Rear Door Speakers	✓		✓	✓	
7	Rear Door Speakers (continued)					
8	Rear Deck Speakers (sedan)	✓	✓		✓	
<b>Tools Required</b> ▶		Phillips Screwdriver	"Stubby" Phillips Screwdriver	Small Flat Blade Screwdriver	Panel Tool	DIN Tools
						Some models require two pairs of tools 

\* If you need additional wiring information, visit us online at [www.crutchfield.com/support/faq.html](http://www.crutchfield.com/support/faq.html)

**Note:** At this time, no aftermarket antenna is available from Crutchfield. A replacement antenna may be purchased from a local dealership.

**CRUTCHFIELD®**  
CRUTCHFIELD.COM  
Copyright 2009 Crutchfield Corporation



033 0051

# DIN Receiver Installation

## NOTES:

**Please read first**

- *Inspect factory receiver harness connector in vehicle. Ensure that the wiring adaptor received from Crutchfield plugs into the vehicle's connector. If the connector is missing or incorrect, please call our Technical Support Department at **1-800-955-9094**.*

1. Secure receiver to mounting bracket following instructions supplied with the installation kit.
2. Connect receiver wiring adaptor to receiver following instructions supplied with adaptor.
3. Hold receiver assembly near dash. Connect receiver wiring adaptor to factory harness. Plug antenna lead into rear of receiver.
4. Slide assembly into dash and push until it snaps into place.
5. Test receiver operation.



**FIGURE 1**

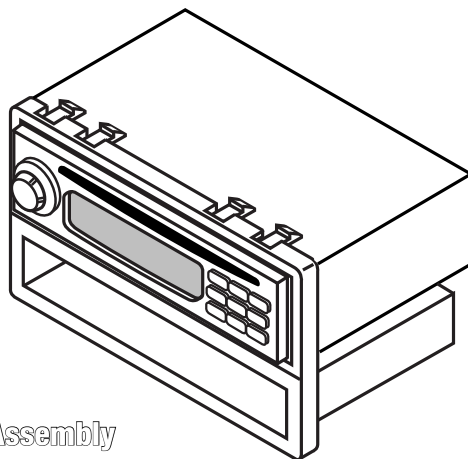

Receiver Assembly



**1-800-955-9094**  
**TECHNICAL SUPPORT**

**CRUTCHFIELD**<sup>®</sup>  
CRUTCHFIELD.COM

Copyright 2009 Crutchfield Corporation **3**

# Front Door Speakers

## NOTES:

### Please read first

- Instructions show factory size speakers or speakers with adaptor brackets only. Cutting or fabricating (not shown) will be required for other speaker sizes.

1. **If equipped with manual windows:** Use a shop rag with a “shoeshine” motion to release “C” clip on rear of window crank and remove crank (Figure 1).
2. Pry out “sail” panel to release two (2) metal clips and remove panel (Figure 2).
3. Remove one (1) phillips screw from center of door release trim. Slide trim toward rear of door to pull from recess and allow trim to hang (Figure 3).
- 4a. **Door Pull Handle Removal - Driver's Door:** Remove one (1) phillips screw from bottom of door pull handle. Pry off front portion of handle from front edge (Figures 4 & 5).
- 4b. **Door Pull Handle Removal - Passenger's Door:** Remove one (1) phillips screw from bottom edge (same location as driver's door - Figure 4). Remove one (1) phillips screw from top of door pull handle (Figure 6). Pry out front portion of handle to remove. Remove two (2) phillips screws from recessed holes exposed by removal of handle (Figure 7).

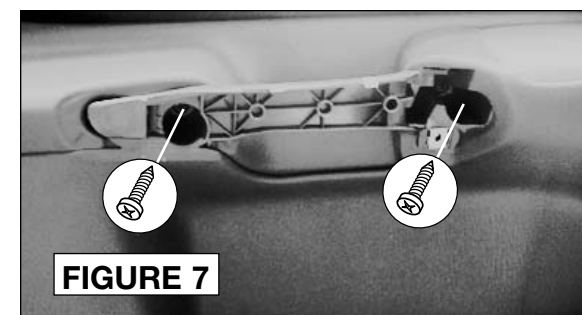
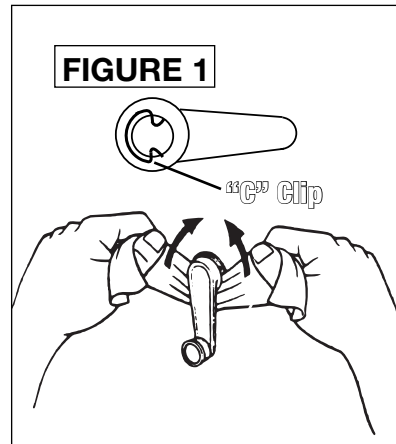

Continued on the next page.

 1-800-955-9094  
TECHNICAL SUPPORT

**CRUTCHFIELD**<sup>®</sup>  
CRUTCHFIELD.COM

Copyright 2009 Crutchfield Corporation

033 0051

## Front Door Speakers (continued)

5. Pry open screw cover in upper front area of door panel and remove one (1) exposed phillips screw (Figure 8).
6. Remove one (1) retaining clip on rear edge of door panel by prying out center pin, then prying out clip (Figure 9).
7. Pry out sides and bottom of door panel to release six (6) retaining clips. Lift panel and disconnect wiring harnesses. Work door release handle through opening and remove door panel (Figure 10).
8. Remove four (4) phillips screws securing speaker. Pull out speaker, disconnect and remove (Figure 11).
9. Connect speaker wiring adaptor of replacement speaker to vehicle speaker connector. Secure new speaker with screws previously removed.
10. Test speaker operation and reinstall door panel by reversing removal steps.

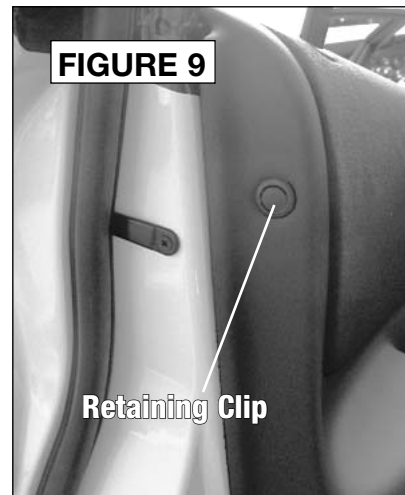
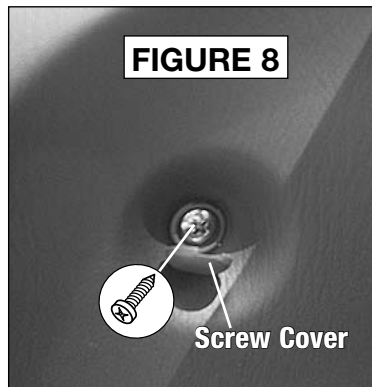

 **1-800-955-9094**  
**TECHNICAL SUPPORT**

 **SAFETY CHECK**

- Check that wires do not interfere with window operation.
- Test door lock and release operation.

**CRUTCHFIELD**  
CRUTCHFIELD.COM

Copyright 2009 Crutchfield Corporation 5

033 0051

# Rear Door Speakers

## NOTES:

**Please read first**

- Instructions show factory size speakers or speakers with adaptor brackets only. Cutting or fabricating (not shown) will be required for other speaker sizes.

1. If equipped with manual windows, use a shop rag with a “shoeshine” motion to release “C” clip on rear of window crank and remove crank. (Figure 1).
2. Pry open screw cover and remove one (1) phillips screw from upper front portion of door panel (Figure 2).
3. Remove one (1) phillips screw from center of door release trim. Slide trim toward rear of door to pull from recess and allow trim to hang (Figures 3).
4. Starting at the bottom front edge, push door pull handle cover upward firmly to release one (1) metal clip. Pry cover and move handle forward to remove (Figure 4). Remove two (2) phillips screws from recessed holes exposed by removal of door pull cover (Figure 5).
5. Remove two (2) retaining clips from rear edge of door panel by prying out center pin, then prying out clip (Figure 6).

**Continued on the next page.**

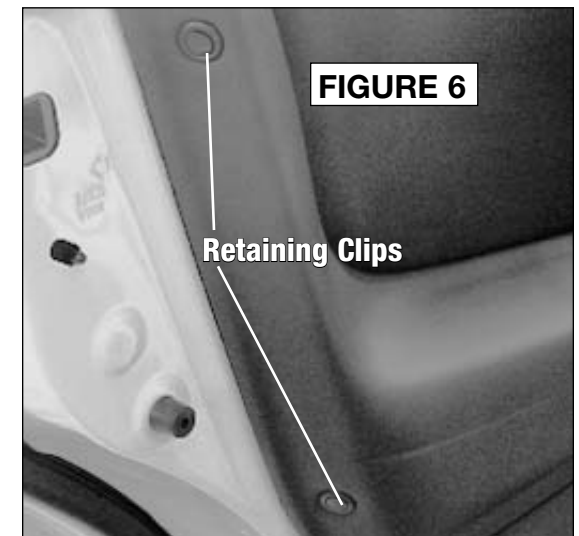
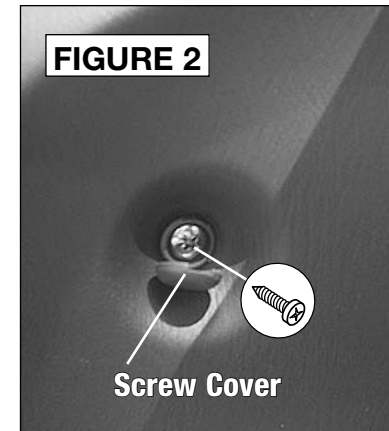
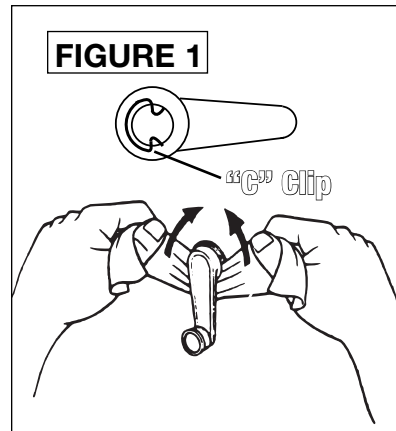

033 0051

## Rear Door Speakers (continued)

6. Pry around all outer edges of door panel to release retaining clips. Work door release handle through opening. Disconnect electrical connectors (if equipped) and remove door panel (Figure 7).
7. Remove three (3) phillips screws securing factory speaker. Pull out speaker, disconnect and remove (Figure 8).
8. Connect speaker wiring adaptor of replacement speaker to vehicle speaker connector. Secure new speaker with screws previously removed.
9. Test speaker operation and reinstall door panel by reversing removal steps.

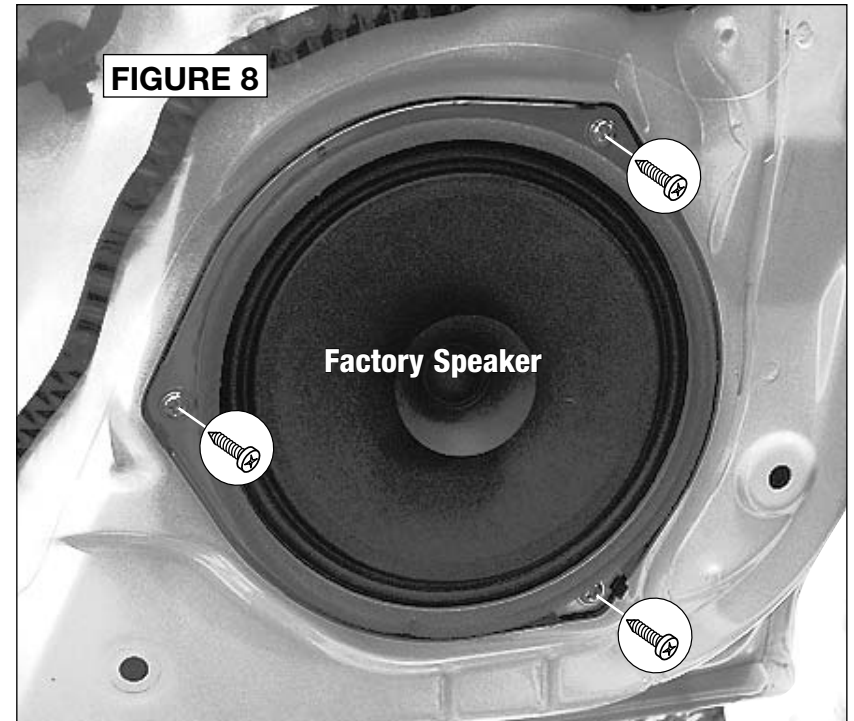

### SAFETY CHECK

- Check that wires do not interfere with window operation.
- Test door lock and release operation.



1-800-955-9094  
TECHNICAL SUPPORT

**CRUTCHFIELD**<sup>®</sup>  
CRUTCHFIELD.COM

Copyright 2009 Crutchfield Corporation

033 0051

# Rear Deck Speakers -- Sedan

## NOTES:

**Please read first**

- Instructions show factory size speakers or speakers with adaptor brackets only. Cutting or fabricating (not shown) will be required for other speaker sizes.

1. Fold down rear seats.
2. Remove five (5) retaining clips from front edge of rear deck panel by prying out center pin, then prying out clip (Figures 1 & 2).
3. Push brake light assembly toward window. Lift assembly, disconnect and remove (Figure 3).
4. Lift rear deck panel straight up to release three (3) clips and set panel aside.
5. Remove four (4) phillips screws securing speaker. Pull out speaker, disconnect and remove (Figure 4).
6. Connect speaker wiring adaptor of replacement speaker to vehicle speaker connector. Secure new speaker with screws previously removed.
7. Test speaker operation and reinstall rear deck panel by reversing removal steps.

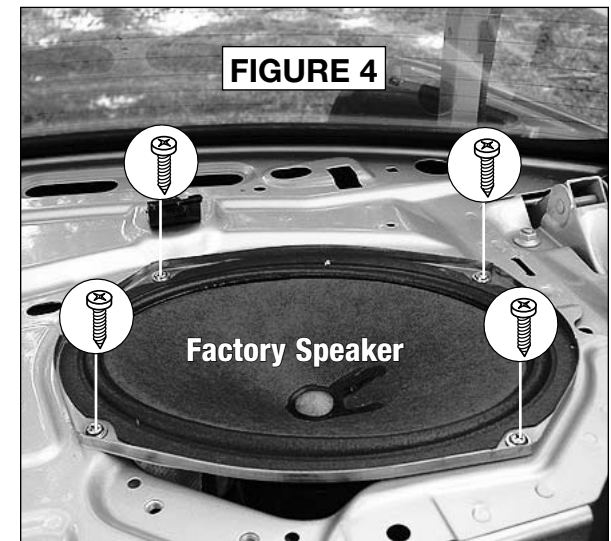
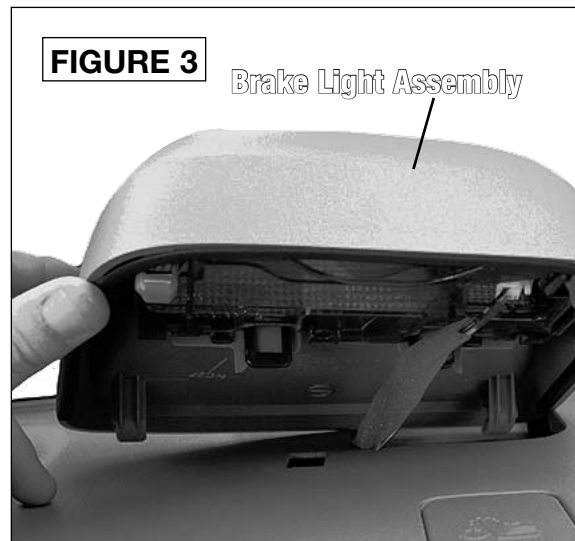
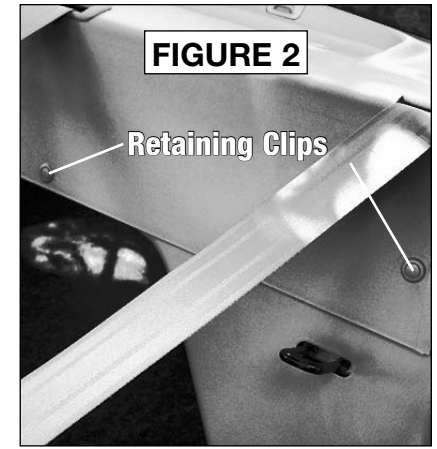
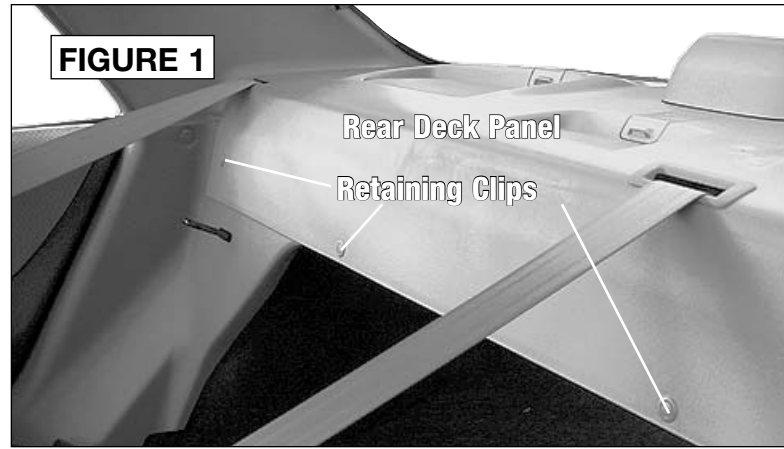

## SAFETY CHECK

- Make sure seats and seat belts are secured to manufacturer's specifications.
- Check rear brake light connection and test operation.



**1-800-955-9094**  
**TECHNICAL SUPPORT**

**CRUTCHFIELD**<sup>®</sup>  
CRUTCHFIELD.COM

Copyright 2009 Crutchfield Corporation 8