

Outline

- The parking sensor system detects obstructions in the blind spot (vehicle front/rear/corners) to a wide extent using ultrasonic sensors and notifies the driver of the obstructions using the indicator and buzzer.

Warning

- **The parking sensor system is a device to assist the driver in confirming safety. It is not a substitute for the driver and cannot guarantee 100 % safety. Do not rely completely on the parking sensor system and drive while confirming the safety of the surrounding area visually.**
- The following circumstances may obstruct the ultrasonic sensor resulting in an accident:
 - Ice, snow, or dirt is adhering to ultrasonic sensor
 - Ultrasonic sensor is covered by foreign matter (such as bumper stickers)
 - Shock is applied to bumper in accident and ultrasonic sensor installation angle is deviated
 - Ultrasonic sensor is exposed to heavy rain or water-spray from road
 - There is another device emitting ultrasonic waves (such as ultrasonic sensor of another vehicle) near ultrasonic sensor
- The parking sensor system may not operate normally under the following conditions:
 - Ice, snow, or dirt is adhering to ultrasonic sensor
 - Ultrasonic sensor is frozen
 - Vehicle is in tilted position
 - Vehicle is parked on steep incline or there is difference in height between lines
 - Obstructions have approached too close to ultrasonic sensor
- The ultrasonic sensor may not detect the following items:
 - Thin objects such as wire or rope
 - Items which absorb ultrasonic waves easily, such as cotton or snow
 - Angular-shaped objects
 - Tall objects protruding at the top
 - Short objects
 - Objects located immediately below bumper, such as wheel stoppers
- The warning alert may activate while driving near parked vehicles/guardrails/walls on a narrow road, or while driving on a slope, gravel road, or grass field. This is a normal effect caused by the system's response to ultrasonic waves, and does not indicate a malfunction.

Function

- The ultrasonic sensor located on the bumper detects an obstruction and the parking assist unit (ultrasonic) informs the driver of the distance between the vehicle and the obstruction using the parking sensor buzzer and the indicator light.

Ultrasonic sensor malfunction detection function

- If the parking assist unit (ultrasonic) detects that there is a malfunction in the ultrasonic sensor circuit, the sound is activated in the following pattern and flashes the indicator light.

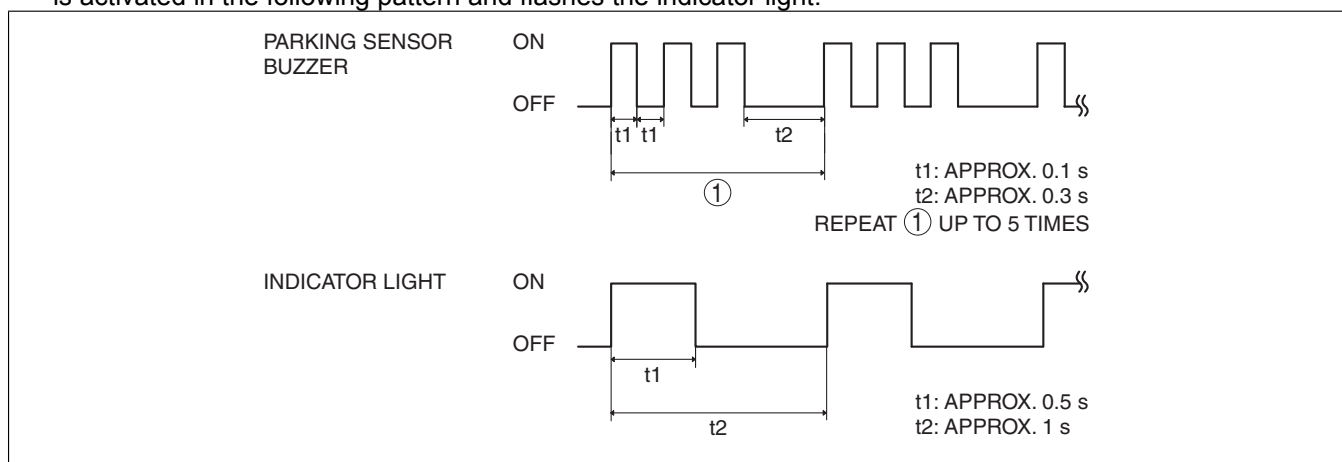

Volume adjustment function

- The parking sensor system can be switched between automatic/manual. Refer to the workshop manual for the switching procedure.

Parking sensor system activation switching function

- The parking sensor system can be switched between automatic/manual. Refer to the workshop manual for the switching procedure.

Structure/Construction Structural view

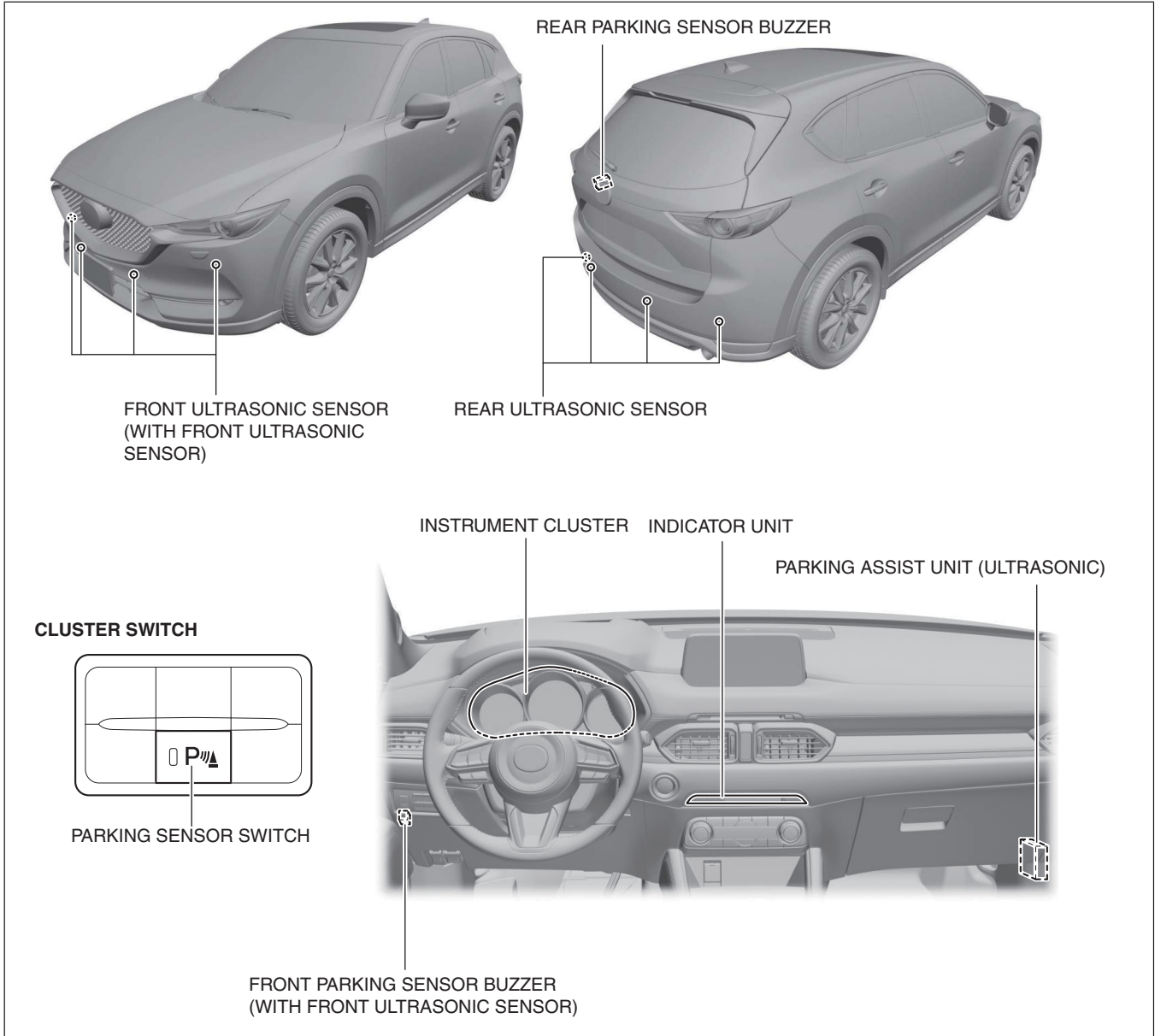

System wiring diagram

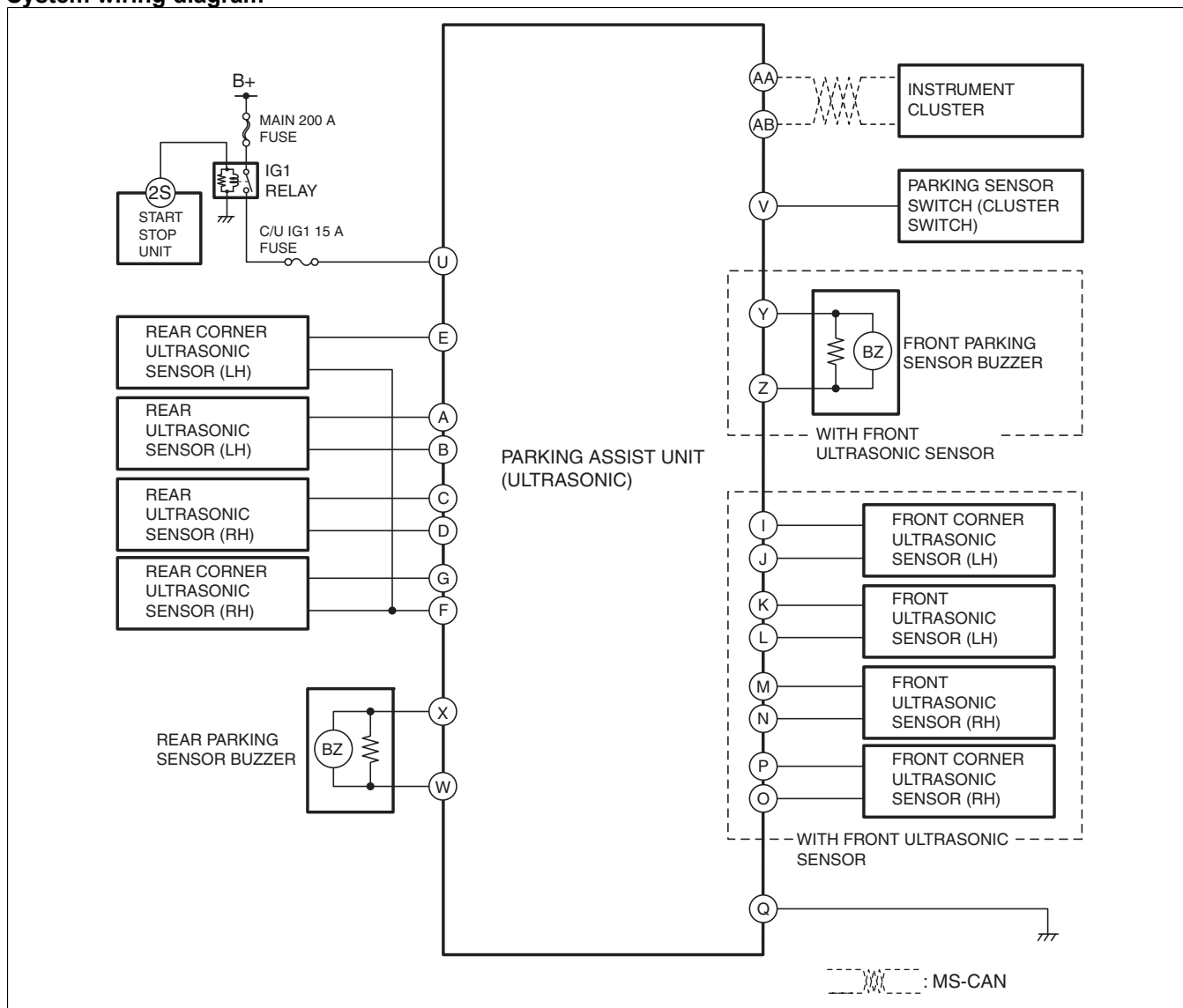

ac5wzn00004442

Operation

Operation condition

- If any one of the following conditions is met, the parking sensor system operates and the parking sensor buzzer activates for **approx. 0.8 s** and the indicator light illuminates.
 - Parking sensor switch turned on (indicator light turns on) (system on) with ignition switched ON (engine on) and vehicle speed of less than **10 km/h {6.2 mph}**
 - Selector lever shifted to position other than R position with ignition switched ON (engine on) and vehicle speed of less than **10 km/h {6.2 mph}** (When parking sensor system activation is only set to automatic)
 - Selector lever shifted to R position with ignition switched ON (engine on) and vehicle speed of less than **10 km/h {6.2 mph}** (When parking sensor system activation is only set to automatic)
- If the parking sensor system operates, the ultrasonic sensor starts to detect obstructions. For the ultrasonic sensor which is operating, refer to the following table.

×: Operates, —: Does not operate

Vehicle condition		Indicator light	Ultrasonic sensor			
Selector lever	Vehicle speed		Front		Rear	
			Corner	Center	Corner	Center
Except R position	Less than 10 km/h {6.2 mph}	×	×	×	—	—
	10 km/h {6.2 mph} or more	—	—	—	—	—

Vehicle condition		Indicator light	Ultrasonic sensor			
Selector lever	Vehicle speed		Front		Rear	
			Corner	Center	Corner	Center
R position	Less than 10 km/h {6.2 mph}	x	x	—	x	x
	10 km/h {6.2 mph} or more	x	—	—	—	x

Obstruction Detection Area

- Each ultrasonic sensor detects obstructions in the following areas.

FRONT
HORIZONTAL DIRECTION AREA

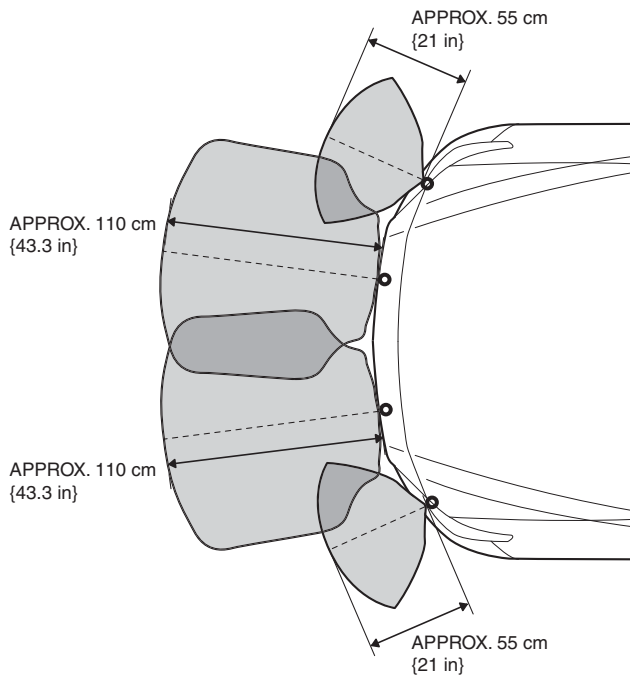

VERTICAL DIRECTION AREA

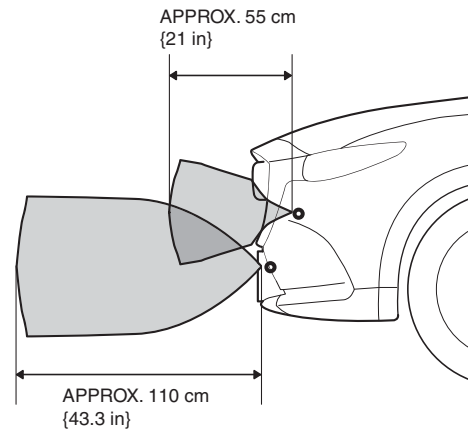

REAR
HORIZONTAL DIRECTION AREA

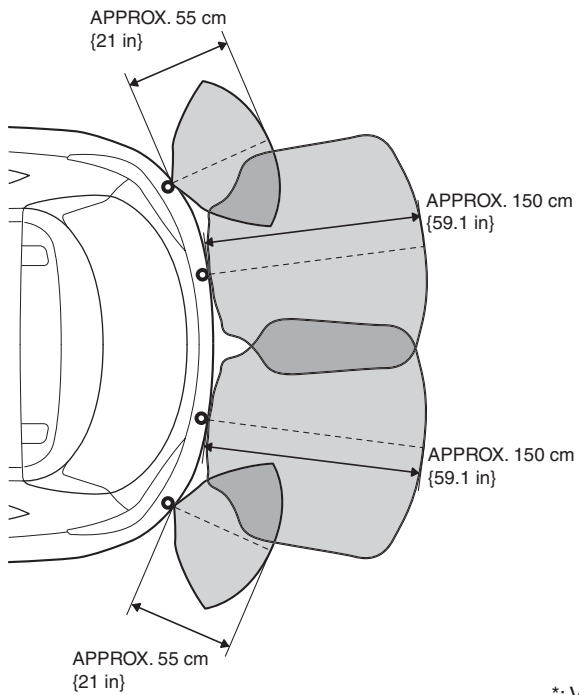



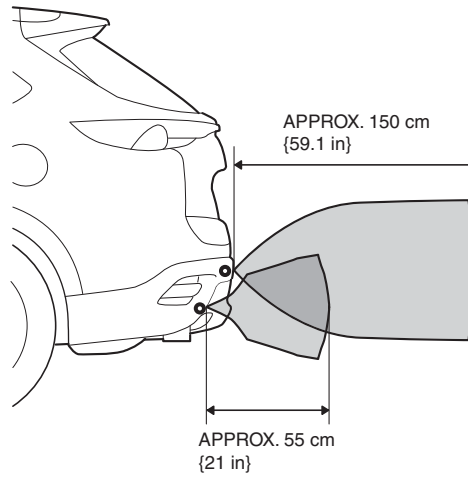







VERTICAL DIRECTION AREA

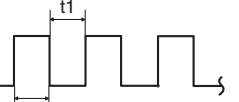
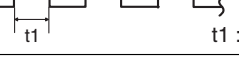

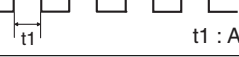
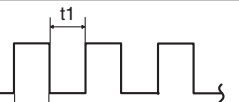
*: VALUES IN ILLUSTRATION ARE FOR REFERENCE.

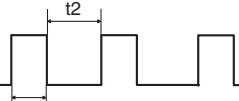
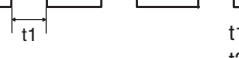
Parking sensor buzzer sound pattern
Obstructions detected

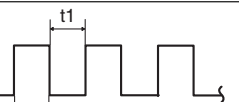
- The changes in the amount of time the parking sensor buzzer activates are as follows:

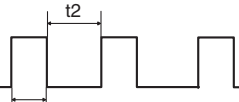
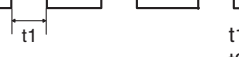
Ultrasonic sensor	Zone	Distance from obstruction	Parking sensor buzzer sound pattern
Front/rear corner ultrasonic sensor	Short distance	Approx. 0.0—25 cm {0.0—9.8 in}	ON ————— CONTINUOUS OFF
	Intermediate distance	Approx. 25—38 cm {9.9—14.0 in}	ON  OFF  t1 : APPROX. 0.055—0.095 s
	Long distance	Approx. 38—55 cm {15—21 in}	ON  OFF  t1 : APPROX. 0.120—0.180 s
Front ultrasonic sensor	Short distance	Approx. 0—40 cm {0—15 in}	ON ————— CONTINUOUS OFF
	Intermediate distance	Approx. 40—50 cm {16—19 in}	ON  OFF  t1 : APPROX. 0.055—0.095 s
	Long distance	Approx. 50—65 cm {20—25 in}	ON  OFF  t1 : APPROX. 0.120—0.180 s
	Maximum long distance	Approx. 65—110 cm {26.0—43.3 in}	ON  OFF  t1 : APPROX. 0.120—0.180 s t2 : APPROX. 0.520—0.780 s
Rear ultrasonic sensor	Short distance	Approx. 0—35 cm {0—13 in}	ON ————— CONTINUOUS OFF
	Intermediate distance	Approx. 35—45 cm {14—17 in}	ON  OFF  t1 : APPROX. 0.055—0.095 s
	Long distance	Approx. 45—60 cm {18—23 in}	ON  OFF  t1 : APPROX. 0.120—0.180 s
	Maximum long distance	Approx. 60—150 cm {24.0—59.0 in}	ON  OFF  t1 : APPROX. 0.120—0.180 s t2 : APPROX. 0.520—0.780 s