

# J&S Electronics

13925 Parkway Dr. P.O. Box 2199 Garden Grove, CA 92842  
 (714) 534-6975 www.jandssafeguard.com

## MP3 units pre-set to 2 Channel Mode

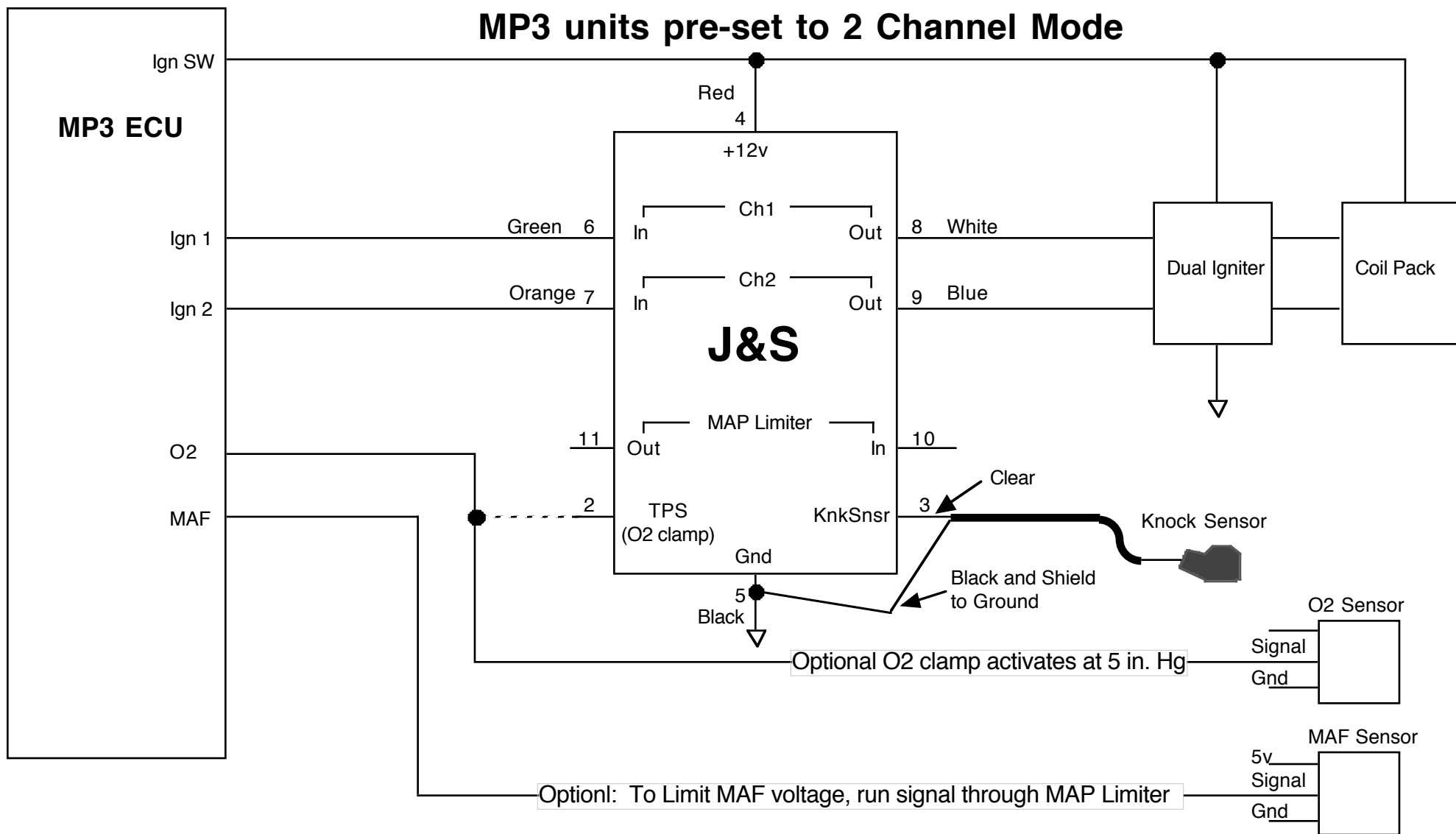

### Switch Settings:

S1 up = 20° max knock retard, down = 10° max knock retard  
 S2 up = retard all mode, down = retard individual mode  
 S3 and S4 select the amount of mid-range RPM retard (if requested)  
 S5 must be down

S3	S4	Degrees
1	1	6
1	0	4
0	1	2
0	0	0