

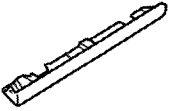





# 1. PARTS

## NOTE

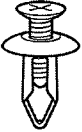
- Before installation, verify that the kit includes all the following parts and that they are free of dirt, scratches, or damage.

| Part  | Name  | Qty      | Part  | Name                          | Qty | Part  | Name                          | Qty      |
|---|---|----------|---|-------------------------------|-----|---|-------------------------------|----------|
|  | Side under spoiler<br>(RH:C236 51P40A)<br>(LH:C236 51 P50A) | 1<br>ea. |  | Clip (small)<br>(G18K 51 SJ3) | 24  |  | Clip (large)<br>(BP4L 51 SJ3) | 6        |
|  | Rivet<br>(B092 51 833)                                      | 2        |  | ★<br>Clip<br>(BC1D 56 145)    | 2   |  | Template (LH,<br>RH)          | 1<br>ea. |
|  | Installation<br>instructions                                | 1        |   |                               |     |   |                               |          |

**NOTE:** The 24 small and 6 large clips are already installed on the side under spoiler. ★Only used for vehicles with mudflaps

## Installation view

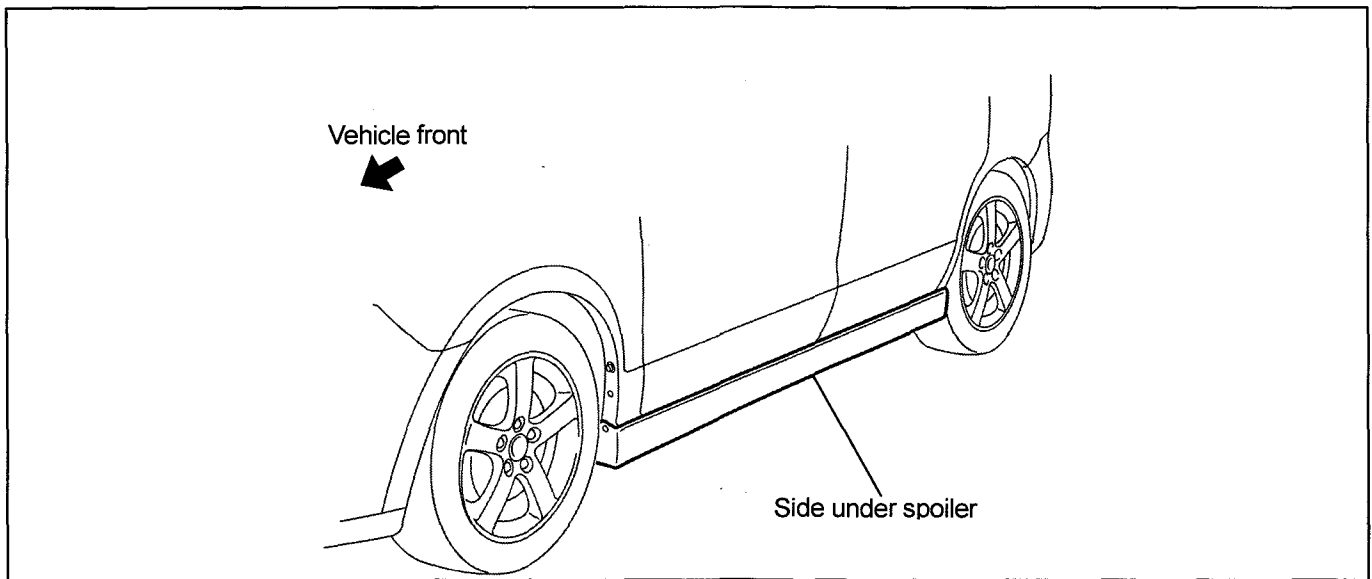

# 2. REQUIRED TOOLS

- ★ Phillips screwdriver (stubby type)
- ★ Flathead screwdriver wrapped with protective tape
- ★ Duct tape
- ★ Punch
- ★ Electric drill (3 mm, 10 mm drill bits)
- ★ Round File
- ★ Scissors
- ★ Soft, clean cloth
- ★ Touch-up paint (Genuine product)
- ★ Isopropyl alcohol (IPA)
- ★ Sealant

### 3. BEFORE INSTALLATION

#### ⚠ CAUTION

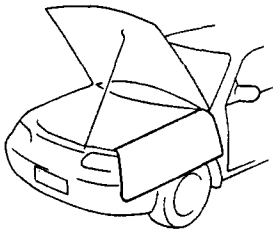
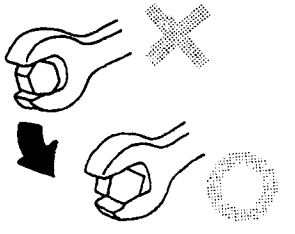
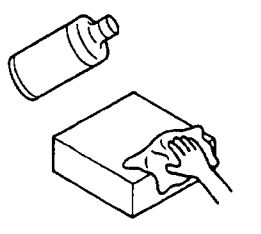
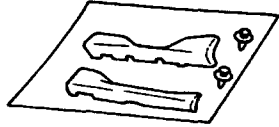
|   |   |  |  |
|---|---|--|--|
| <p>Be sure to cover the vehicle body with protectors or mats to prevent stains, scratches and damage when removing/installing the vehicle parts</p> | <p>Use the most appropriate (size, use) tool for each task and perform the work correctly. Otherwise, the parts may be damaged.</p> | <p>When installing parts with double-sided adhesive tape, carefully clean the adhesive surface and keep it away from dust or dirt. Otherwise, parts could fall off and be damaged.</p> | <p>Place the removed parts and kit accessories on a protective sheet to prevent scratches.</p> |
|    |    |    |             |

#### ⚠ CAUTION

- The side under spoiler installation work requires two or more people.
- The side under spoiler and the mudguard cannot be equipped together.

#### NOTE

- Refer to the Workshop Manual for removal and installation of vehicle parts. Not following the procedures for removal/installation in the Workshop Manual could result in an accident or vehicle malfunction.

### 4. PART REMOVAL

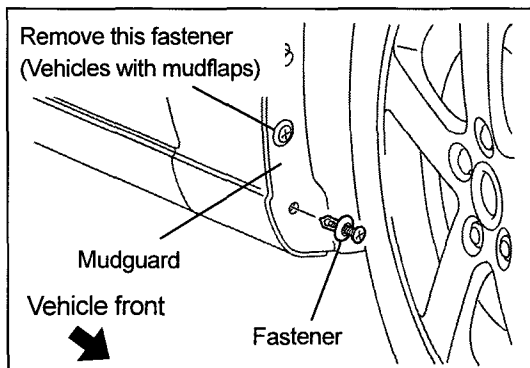

#### NOTE

- The figure shows the right side, however, perform the same procedure for the left side.

#### Fastener removal

1. Remove the fastener (1).  
(For vehicles with mudflaps, remove the fasteners (2), and then the mudguard)

#### NOTE

- The removed fasteners are not used to install this accessory.

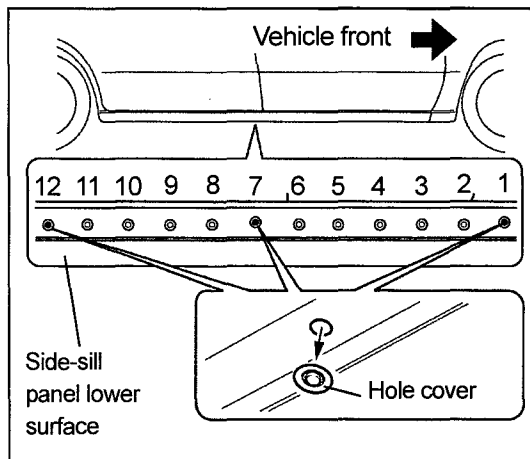

#### Hole cover removal

1. Remove the hole covers from the lower surface of the side sill panel using a flathead screwdriver wrapped with protective tape as shown in the figure (1st, 7th, 12th hole covers from vehicle front).

#### NOTE

- The removed hole covers are not used to install this accessory.

## 5. SIDE UNDER SPOILER INSTALLATION

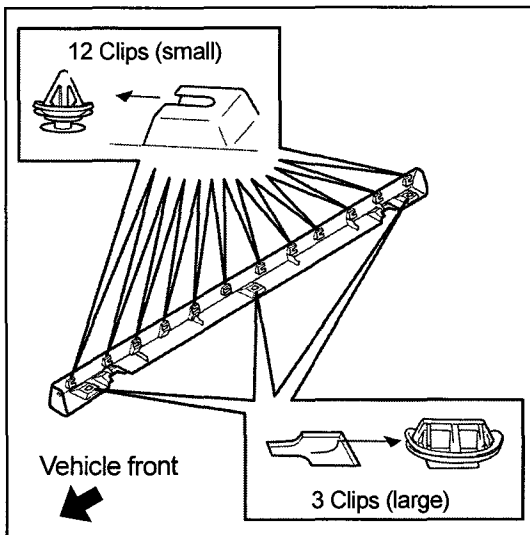

### NOTE

- The figure shows the right side, however, perform the same procedure for the left side.

### Clip Removal

- Detach the 12 clips (small) and 3 clips (large) installed to the side under spoiler.

### CAUTION

- The detached clips will be reused. Be careful not to damage or lose them.

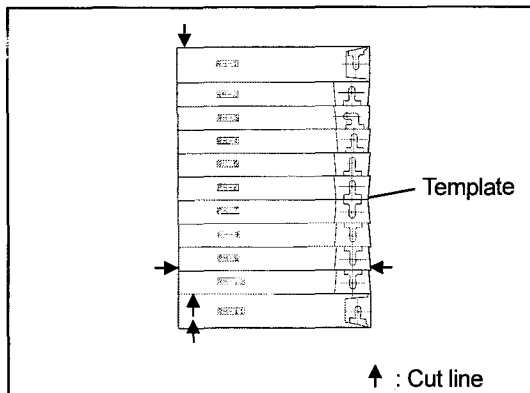

### Body hole drilling

- Cut out the templates with scissors along the cut lines.

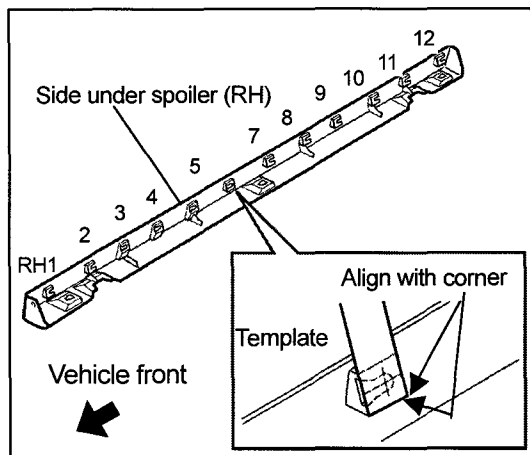

- Affix the templates to the side under spoiler with the printed side facing the side under spoiler, and aligned with the corner of the clip as shown in the figure. (12 locations)

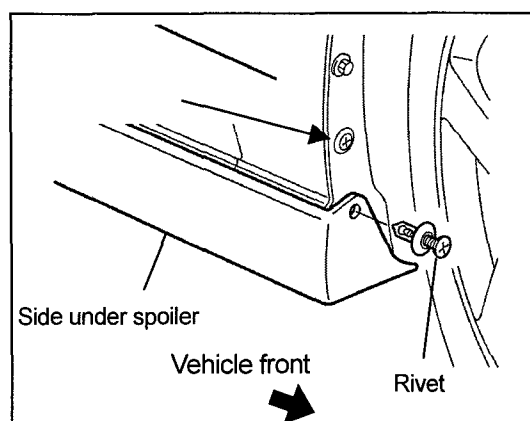

- Install a clip (1) to the upper hole where the mudflap was installed. (Vehicles with mudflaps)
- Attach the side under spoiler to the installation position so that there are no gaps, and temporarily fix it using the rivet (1).

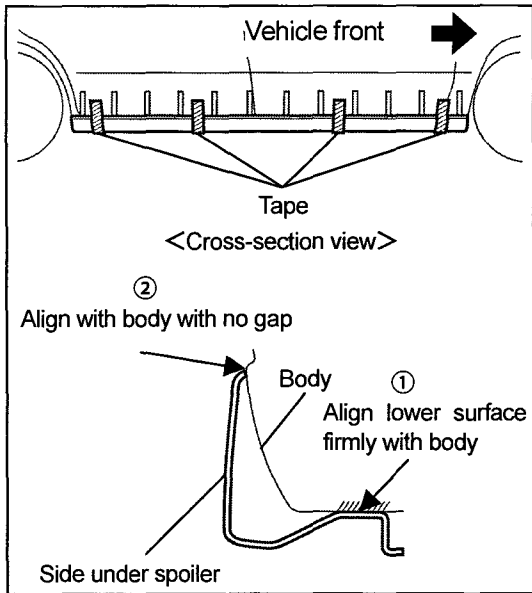

- Securely align the lower surface of the side under spoiler ① to the body, and press firmly so that there is absolutely no gap on side surface of the side under spoiler. (Refer to the cross-section view)
- Temporarily fix the side under spoiler with tape.

**CAUTION**

- Be careful of the alignment of the side under spoiler with the body, and make sure that it contacts the lower surface of the vehicle body and its height is equal from front to back.

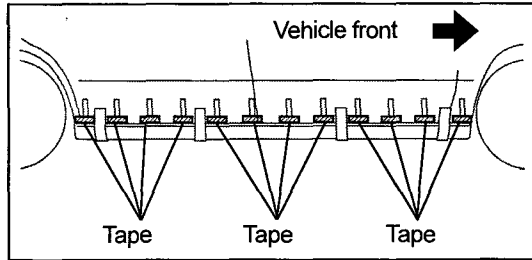

- Set the templates along the bodyline and attach with tape.

**CAUTION**

- Make sure the templates are not twisted or detached when affixing them to the body.

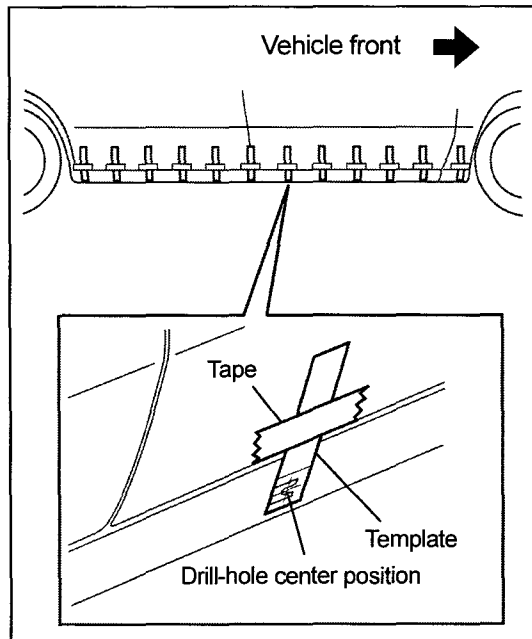

- Remove the rivet (1) temporarily installed in Step 3, and detach the side under spoiler with the templates left affixed to the vehicle.

**CAUTION**

- When detaching the side under spoiler, be careful that the templates do not slip or become ripped.

- While keeping the templates set to the shape of the body, punch marking holes through the center of the template using a punch. (12 locations)

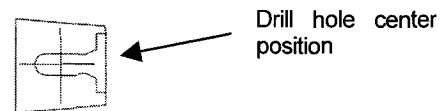

**NOTE**

- Punch holes in the center of each drill-hole mark with the templates left affixed.

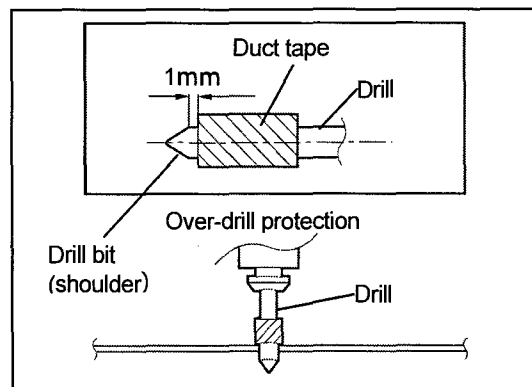

- Peel off the templates (12 locations).

- Wrap the drill bit with duct tape as shown in the figure.

**CAUTION**

- Be careful when handling drills and other sharp objects.
- To prevent scratching and over-drilling, always wrap the drill bit with duct tape.

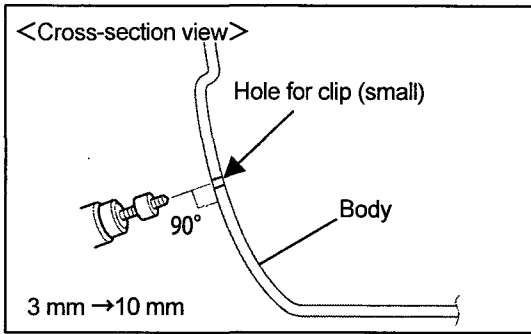

12. With the drill bit pointed perpendicular to the body, drill 3 mm holes in the drill mark positions (12 locations).
13. Expand the 3 mm holes (12 locations) to 10 mm using the drill.

**CAUTION**

- The drill bit is hot after drilling; be careful not to burn yourself.

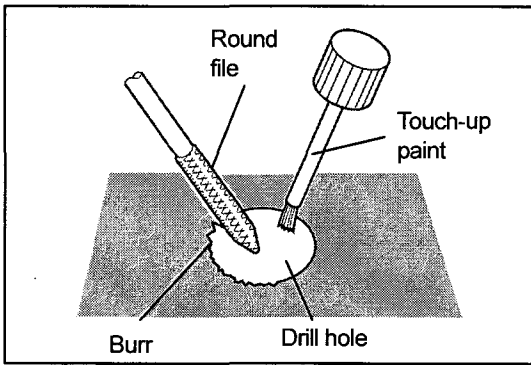

14. Remove any burrs around the drilled hole with a round file.

**CAUTION**

- Make sure to remove burrs from the surface so that the body surface is smooth.

15. Apply sufficient sealant to prevent rust.
16. After the sealant has dried, apply touch-up paint.

**CAUTION**

- Make sure anti-rust protection is carried out properly.

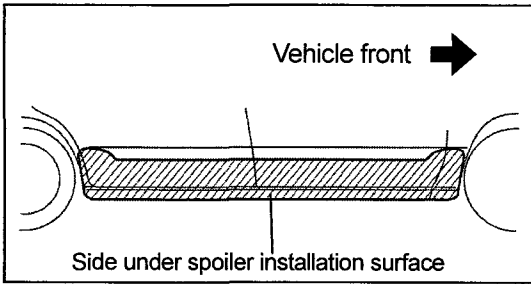

### Side under spoiler installation

1. Use a soft cloth dampened with IPA (isopropyl alcohol) to clean the surface of the vehicle where the side under spoiler is to be installed.

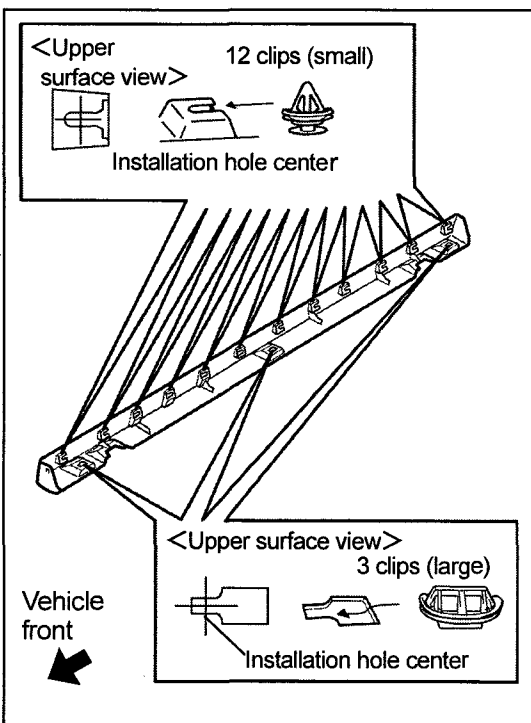

2. Install the 12 clips (small) and 3 clips (small) to the side under spoiler.

**CAUTION**

- Do not insert the clips completely into the slots. Insert them only up to the center of the installation holes. The side under spoiler cannot be installed if the clips are inserted completely into the slots.
- Install the clips (large) in the direction shown in the figure.

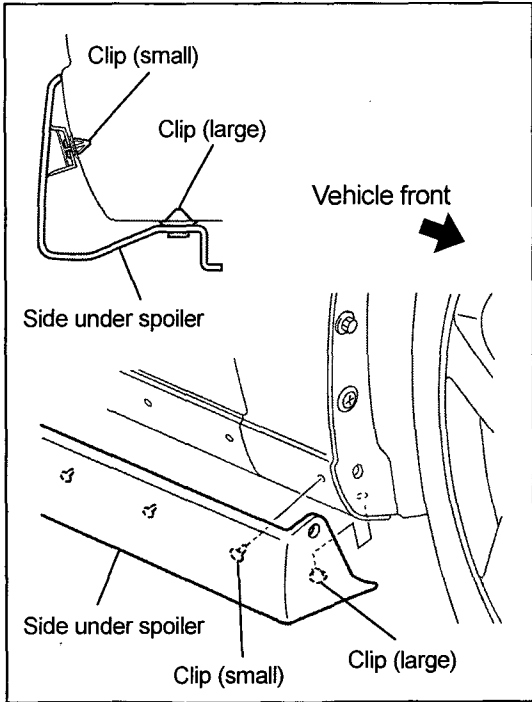

3. Align the side under spoiler clips with the installation holes, inserting the 12 clips (small) on the upper side first, then the 3 clips (small) on the lower side.

**CAUTION**

- Push the clips in slowly. If the clips are pushed in with excessive force, they will deform and it may become difficult to insert them.
- Make sure the installation is in alignment with the vehicle.

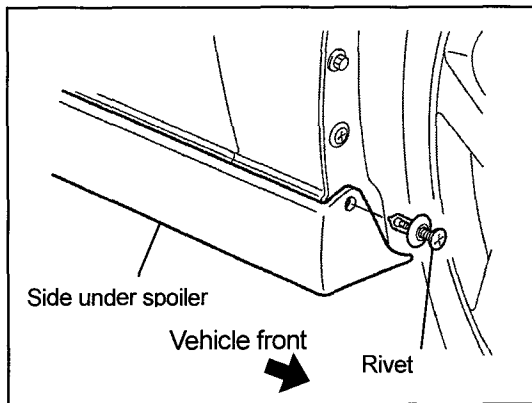

4. Install the rivet (1) to the front end of the side under spoiler and secure it.