

FRONT SUSPENSION

id021300101000

Outline

Front Lower Arm Bushing

- A fluid-filled type front lower arm bushing has been adopted.
- By filling the inside of the front lower arm bushing with fluid, the damping coefficient is increased and the vibration to the steering is suppressed.

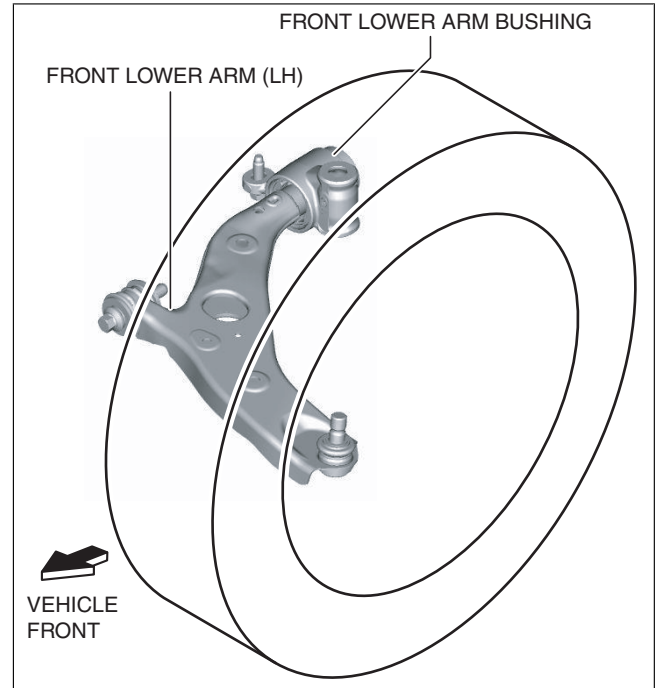

ac5uun00002741

Front Crossmember

- A strut type front suspension has been adopted.
- The connection area of the front crossmember and body is a 6-point rigid mount type.

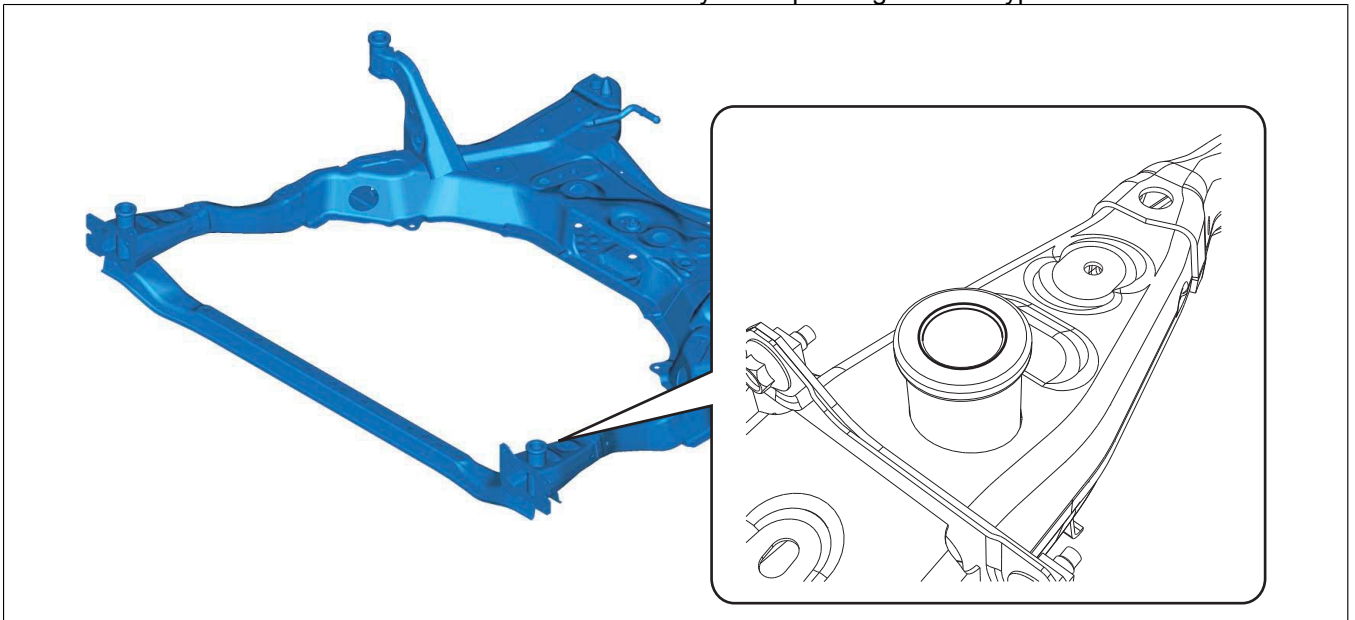

ac5ijn00003619

- The cross-section on the center member of the front crossmember has been expanded and the longitudinal offset of the front lower arm installation position reduced to realize an optimized framework.

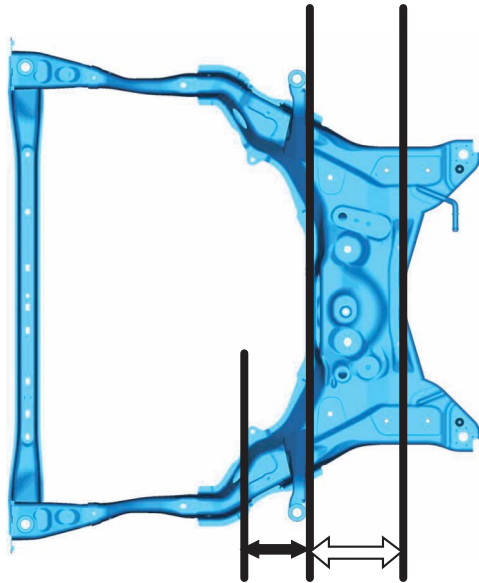

◄ : BETWEEN FRONT LOWER ARM ATTACHMENT POSITION AND FRONT CROSSMEMBER (CENTER MEMBER)

◄◄ : FRONT CROSSMEMBER (CENTER MEMBER) WIDTH

ac5uun00002742

- For the front crossmember, the welded part of the flange has been eliminated (flange-less), the cross-section expanded and the connection rigidity of the welded parts improved to achieve both rigidity and light weight.

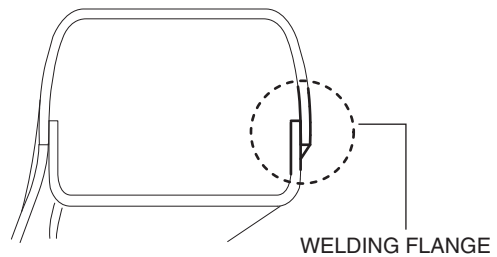
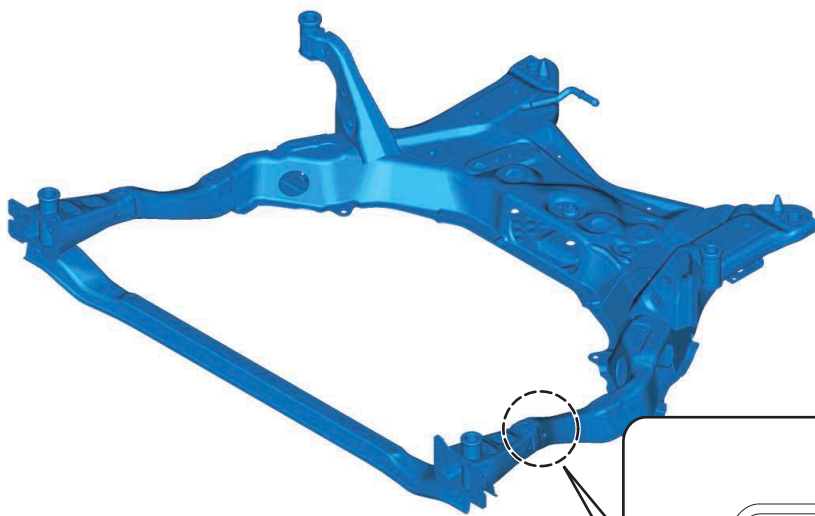

ac5uun00002743

- The caster angle and caster trail of the front suspension have been increased.

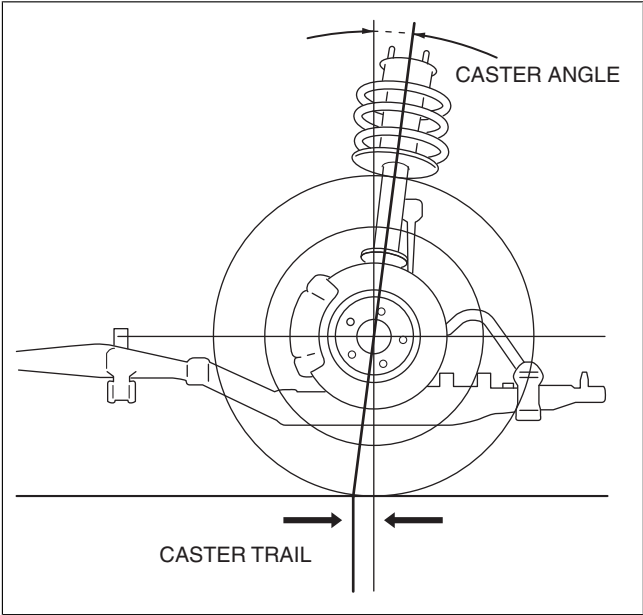

ac5uun0000292

**Construction
Structural View**

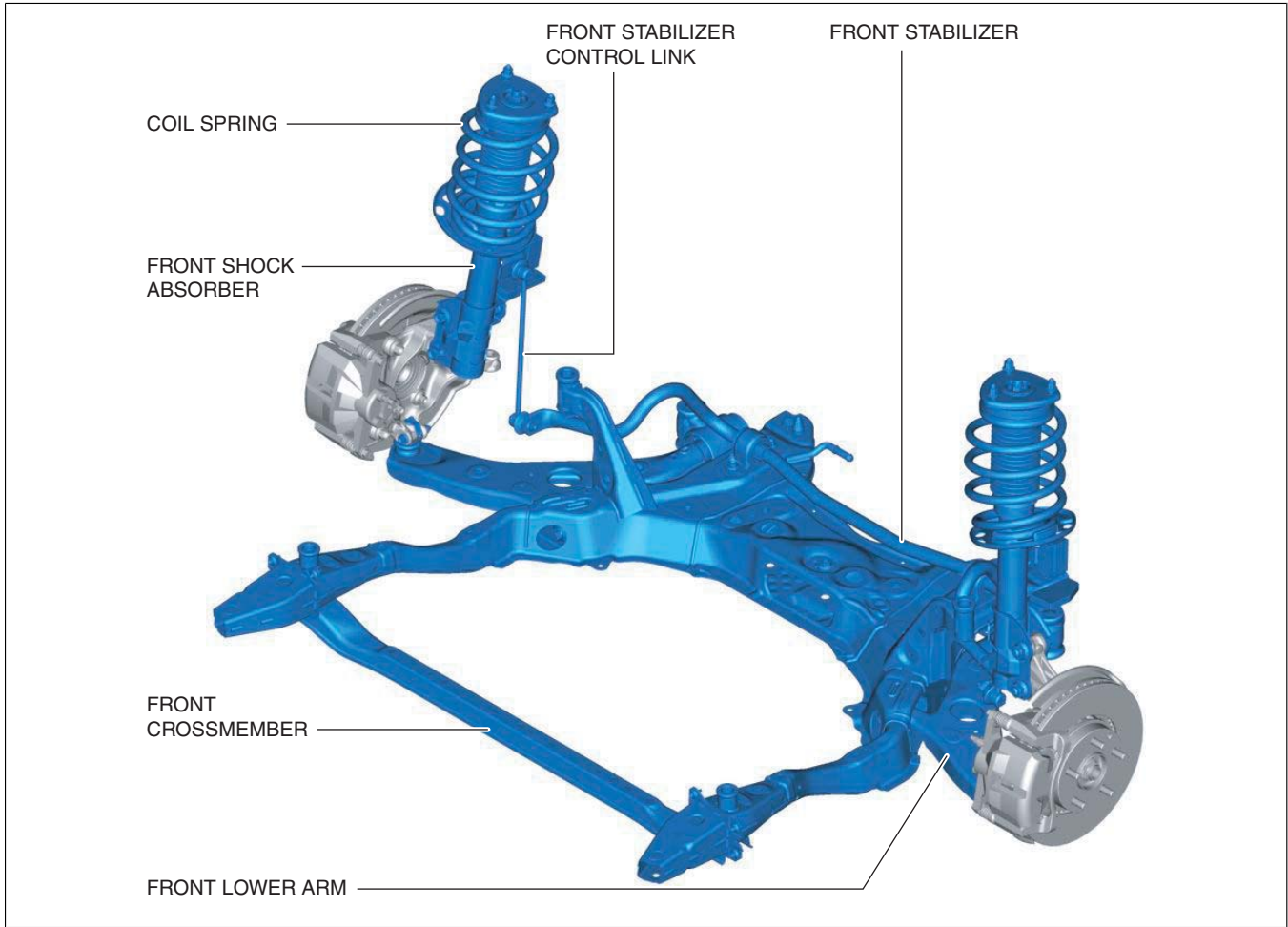

ac5uun00002744