

DTT

DUAL TURBO TIMER DIGITAL COMPACT

DC



Features

- Auto Timer**
- Manual Timer**
- Boost Guage**
- Peak Hold Display**
- Boost Warning**
- Stop Watch**
- 5 Lap Times**

Blitz Performance Sales Inc.
17300 Railroad St. #B
City of Industry, CA 91748
Tel 626 839-8350
Fax 626 839-8340
www.Blitz-Performance.com

Warning

- *Installation should start after the contents of this instruction manual is read and fully understood
- *Injury may be cause by improper installation.
- *Installation should be entrusted to a professional technician.
- *Double check all wire connections. Avoid all plastic or painted surface for ground wire. Bad ground may cause poor actuation of turbo timer and cause the breakdown of this product.

Caution for installation work

1. Vehicles equipped with computer preset automatic steering.
 - Note that steering wheel does not tilt up even if the ignition key is pull out when the product is installed in vehicles equipped with computer preset automatic tilt steering.
2. Vehicles equipped with automatic light control.
 - Note that the light may be kept on even after the timer is off. When the turbo timer is actuated with the light switch is AUTOMATIC. The light will remain on after the car shuts off.
3. Actuation of air conditioner.
 - Depending on the types of automobile, extremely large electric current may flow and cause breakdown of the turbo timer when the turbo timer and air conditioner is simultaneously actuated. Be sure to turn off air condition when the turbo timer is actuated.

Installation Procedure

1. Remove lower instrument panel as shown in figure 1 #B.
2. Remove upper and lower steering column cover as shown in figure 1 #A.
3. Locate the key ignition coupler.

Figure 1

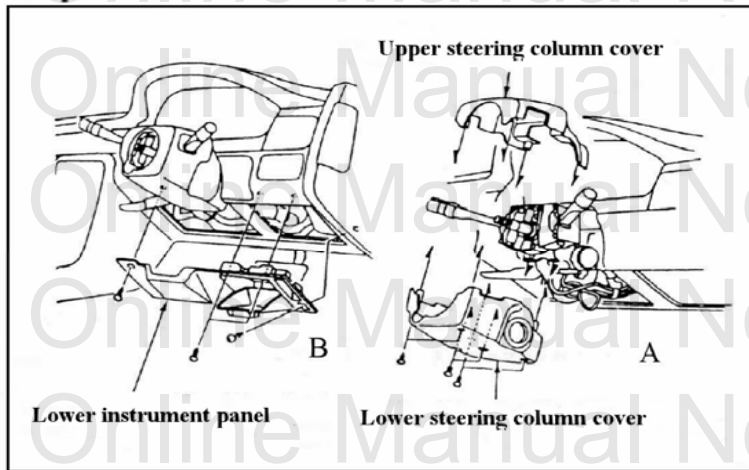

*Illustration shown above is reverse.

4. Pull out the starter coupler located in figure 1 and connect the genuine Blitz turbo timer harness (sold separately) into the starter coupler.
5. Connect the Blitz turbo timer harness to the 3 pin connector as shown below.
6. Connect 3 pin harness to 4 pin harness.
7. Ground all black wires as shown in figure 2. Ground should be metallic portions and avoid painted surfaces.
8. The purple wire should be grounded or hooked up to the hand break.
9. Connect the vacuum tube to a source behind the throttle body. Use the supplied connector, " T ", and hose.

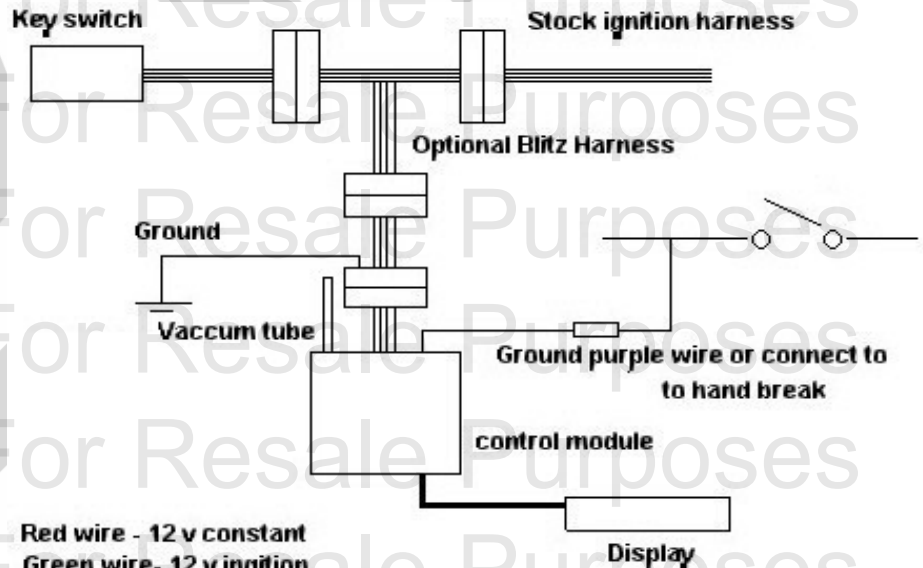

Red wire - 12 v constant
Green wire - 12 v ignition
Blue wire - accessory
Black wire - ground
Purple wire ground or hand break

Instructions for installing safety features

***Important-the parking brake wire (purple) must have ground signal at all times, either by grounding the wire or reading ground signal from the parking brake wire. If purple wire is not install correctly, the turbo timer will automatically shut off when key is taken out.**

1. Parking brake. Purple wire
 - A. Single wire parking brake. connect purple wire as shown in figure A.
 - B. More than one wire.
 - a. Turn key to ON position. (do not start engine)
 - b. Use test light to find the wire with 12V power when the parking brake is down. Connect to that wire as shown in figure B.

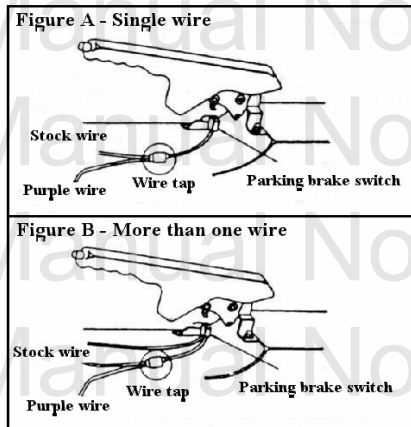

CAUTION: Parking brake can be bypass if purple wire is grounded.

*Engine will shut off if the parking brake is release at anytime during count down.

2. Confirmation

-Check if all wires are connected securely. Insufficient wiring may cause poor actuation of the product. In the worst case, it may result in the breakdown of the engine.

-Be sure wiring are neatly installed without any interference with surrounding parts. Short circuit may occur due poor connections. In the worst case, it may result in breakdown or the engine.

CAUTION: When confirming actuation of turbo timer, be sure that the gear is in neutral or parking position and the foot is on the brake. Also be sure there is no one around the vehicle.

In case of Failure of product

Check the following before concluding there is any failure of this product.

1. Check if wires is connected securely and connectors is inserted rigidly.
2. Check if ground wire is ground correctly.
3. Check if tap is securely connected.



1 2 3

- 1 - Power Button
- 2 - Minute Button (Start / Stop for stop watch function)
- 3 - Second Button (Lap button for stop watch function)

Settings

When the Timer is activated the modes will appear as follows:

- 1 - Automatic Timer
- ↓
- 2 - Manual Timer
- ↓
- 3 - Boost Gauge
- ↓
- 4 - Peak Hold Display
- 5 - Warning
- ↓
- 6 - Stop Watch
- 7 - Lap Time Display
- ↓
- 8 - Off

Press the POWER to button to switch to the next mode.

Description of Modes

The idling time is automatically set by the timer. Idling time varies on what mode the auto timer is set on and the variations of the vehicles boost pressure.

-Mode display is located on the left side of LCD

1. Automatic Timer A



When the FATT DC is turned on the Automatic Timer mode will be activated.

The "TIMER A" will be displayed



To set the minimum time of the auto timer press the MINUTE button once and the screen will flash. Then press SECOND button to set the base time between 0 to 50 seconds.

** When the A appears, the Automatic Timer function is activated.

Press the MINUTE button on the Boost or Peak hold display to turn the Automatic Timer on or off. Make sure that the letter A appears. The A means auto timer is activated

There are 4 different auto timer modes. Press the MINUTE button twice when in Automatic Timer Mode. The automatic timer modes will go as follows

A - H ▶ A - S ▶ E - L ▶ E - H ▶ A - L

Press the SECOND button to switch between the modes.



A - L mode will start to calculate time to automatic function mode after 0.4 hkPa. Low setting

A - H mode will start to calculate time to automatic function mode after 0.6 hkPa. Medium setting

A - S mode will start to calculate time to automatic function mode after 0.8 hkPa. High setting

E - L mode will add time according to how long the ignition has been on roughly 55 seconds per hour

E - H mode will add time according to how long the ignition has been on roughly 130 seconds per hour



2 - Manual timer



Press the POWER button twice to get to the manual timer mode. The screen will display "TIMER" The will not be an A visible.

To set the time of the manual timer press the MINUTE button to set the number of minutes you want the car to idle after the vehicle has been shut off. Press the SECOND button set the number of seconds desired. You can choose idling times between 0 to 10 minutes

** To activate the manual timer go to the BATTERY or TEMPERATURE display and press the MINUTE button. Make sure that the letter A does not appear.

3 - Boost Display

When the unit is first turned on press the POWER button three times to display the Boost display mode. The Boost is shown in KPA



When on Boost display press the MINUTE button to activate the Automatic Timer function the letter A will appear.



When on Boost display press the MINUTE button to activate the Manual Timer function the letter A will disappear.

4 - Peak Hold Display

When the unit is first turned on press the POWER button four times to display the Peak Hold Display mode. This will the highest boost achieved.



When on Peak Hold display press the MINUTE button to activate the Automatic Timer function the letter A will appear.



When on Boost display press the MINUTE button to activate the Manual Timer function the letter A will disappear.

To clear Peak Hold display press the second button for.

5 - Warning

When the unit is first turned on press the POWER button five times to display the Warning display mode. The timer will sound and the screen will turn red if the vehicle passes the preset warning.



To set the warning use the Minute and Second buttons. The minute button will set the hundredth place and the second button will set the thousandth place.

To turn warning off make sure the 3 dashes are displayed.

6 - Stop Watch

When the unit is first turned on press the POWER button six times to display the Stop Watch mode. This can be used to record the time it takes to get to point A to point B. The Stop Watch will record times up to 9 minutes and 59 seconds.

Use the MINUTE button for the Start and Stop Function keys. Use the SECOND button for the lap button.



To start and stop the Stop Watch press the MINUTE button. Press the Second button to jump to another Lap. There is 5 Laps available. If the laps are full the LCD will display full when trying to record another Lap. To clear the time press the SECOND button and hold it down for 5 seconds.

7 - LAP TIMES

When the unit is first turned on press the POWER button seven times to display the Lap mode. The Lap mode can display up to 5 recorded times.



Press the SECOND button once to scroll through and view the recorded lap times. Press the second button and hold it down for 5seconds to CLEAR all the recorded times.

8 - Off

When the unit is first turned on press the POWER button eight times to display the Off mode. The leave the display on off mode and the FATT DC will turn off automatically.



Press the POWER button to turn on the turbo timer.

LCD DISPLAY

CONTRAST

When the FATT DC is turned off the user can adjust the contrast by pressing the MINUTE and SECOND button. The user can adjust the illumination between 0 to 100.

BAR DISPLAY

When the Turbo Timer is on Auto Timer E Mode the user can have different bar displays. In order to do this select E - H or E - L mode in the Auto Timer setting. When the E mode is activated the Bar Display will move side to side.

To change the Bar Display press the SECOND button down for 3 seconds and the display will change. There will be 4 possible displays. 3 of the displays will be automatically moving and the fourth display will move according to the vehicle boost.

** This automatic back and fourth function only works on the E mode of the Auto Timer setting

A and B switch

There is a switch on the control module. A is for most vehiclce applications. The B switch is for vehicles with low ignition pulses.