

[< Previous](#) [Next >](#)

2014 - CX-9 - DriveLine/Axle

DIFFERENTIAL OIL REPLACEMENT

1. Place the vehicle on level ground.
2. Remove the filler plug.

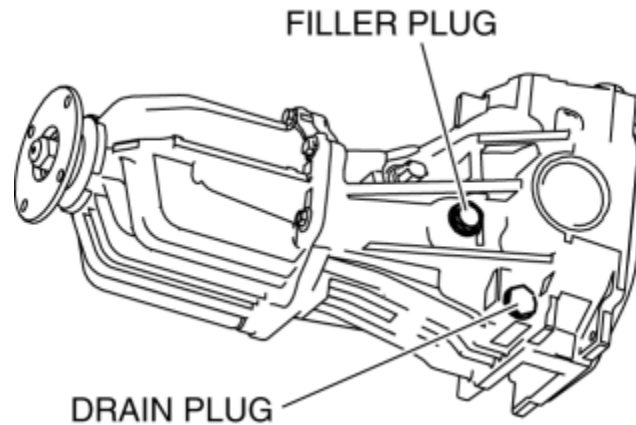

3. Remove the drain plug and drain the differential oil into a container.
4. Install a new washer and the drain plug, and tighten.

Tightening torque

- 39.2—53.9 N·m {4.0—5.4 kgf·m, 29.0—39.7 ft·lbf}

5. Add the specified differential oil from the filler plug until the level reaches the brim of the plug hole.

Rear differential oil

- Specified oil grade: API service GL-5
- Specified oil viscosity: SAE 80W-90
- Capacity (approx. quantity): 1.0 L {1.1 US qt, 0.9 Imp qt}

6. After filling with differential oil, perform oil level inspection.
7. Install a new washer and the drain plug, and tighten.

Tightening torque

- 39.2—53.9 N·m {4.0—5.4 kgf·m, 29.0—39.7 ft·lbf}

[< Previous](#) [Next >](#)

[Back to Top](#)

© 2012 Mazda North American Operations, U.S.A.