

© 2012 Mazda Motor of America, Inc.

<b>Subject:</b>  CHATTER NOISE FROM STEERING COLUMN COVER	<b>Bulletin No:</b> 09-027/12
	<b>Last Issued:</b> 07/17/2012

## APPLICABLE MODEL(S)/VINS

2013 CX-5 vehicles with VINs lower than JM3KE\*\*\*\*\*130551 (produced before June 13, 2012)

## DESCRIPTION

When driving on rough roads, some vehicles may exhibit a chattering noise which is heard around the upper steering column cover (A). The noise stops when pressing down on the upper column cover.

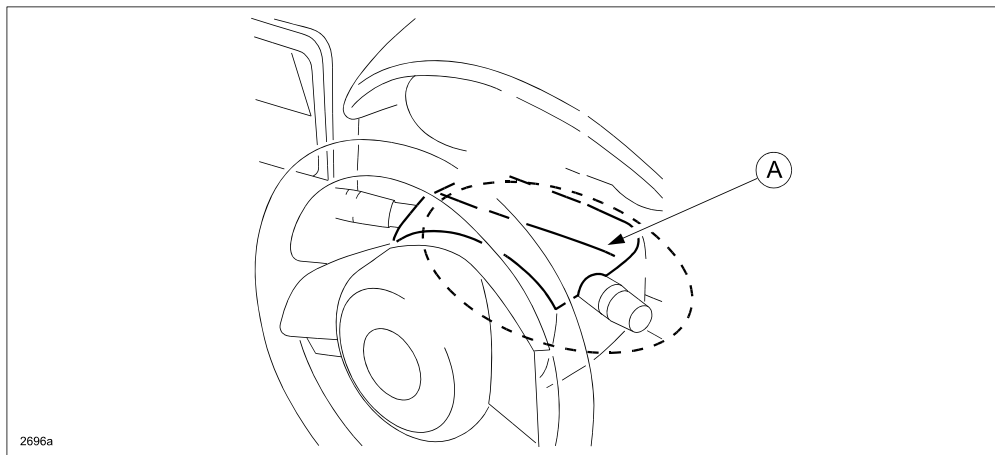

Due to variations in assembly, the start/stop unit harness bracket may interfere with the upper column cover causing the chattering noise.

Customers having this concern should have their vehicle repaired using the following repair procedure.

## REPAIR PROCEDURE

1. Verify the customer concern.
2. Remove the upper column cover according to the MS3 online instructions or the Workshop Manual (section 09-17 COLUMN COVER REMOVAL/INSTALLATION).
3. Cut four (4) pieces of 0.25 mm thickness fabric (from Noise Repair Kit) into 15 mm x 25 mm (0.6 in. x 1 in.) size squares.
4. Affix two (2) layers of fabric squares to both areas shown below (A), inside the upper column cover.

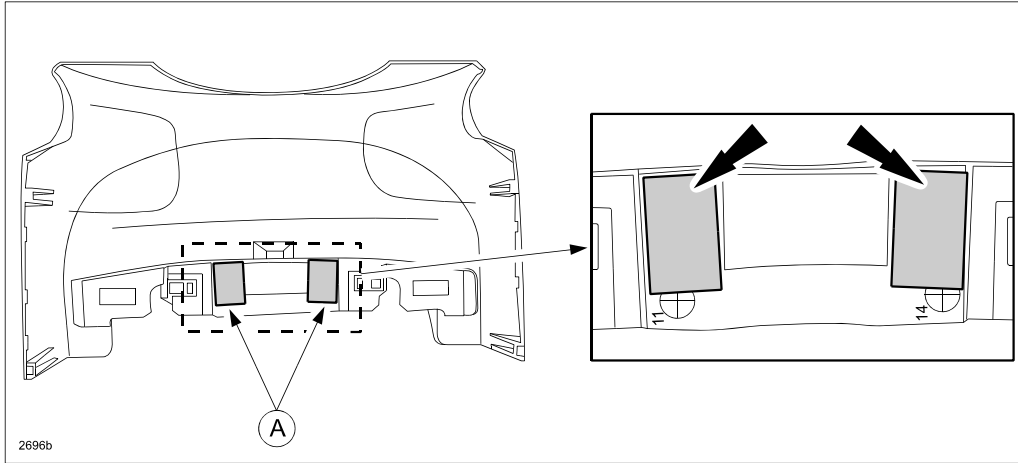

5. Reinstall the upper column cover according to the MS3 online instructions or the Workshop Manual (section 09-17 COLUMN COVER REMOVAL/INSTALLATION).
6. Verify the repair.

## PART(S) INFORMATION

Part Number	Description	Qty.	Notes
TA01-76-100	Noise Repair Kit	1	0.25 mm thickness non-woven fabric included in kit.

## WARRANTY INFORMATION

**NOTE:**

- This warranty information applies only to verified customer complaints on vehicles eligible for warranty repair.
- This repair will be covered under Mazda's New Vehicle Limited Warranty term.
- Additional diagnostic time cannot be claimed for this repair.

Warranty Type	A
Symptom Code	82
Damage Code	97
Part Number Main Cause	KD45-60-220C-02 (Upper column cover)
Quantity	0
Operation Number / Labor Hours:	XXH51XRX / 0.2 Hrs.

**NOTE:** The cost of the necessary parts of the repair kit are included in the labor allowance.