

FRONT BRAKE CALIPER REMOVAL/INSTALLATION [WITH 2-PISTON FLOATING CALIPER]

id041100003w5

Special service tool (SST)

49 G034 204
Support block



Gasket
Quantity: 2
Location of use: Front brake hose

Oil and Chemical Type

Brake fluid type
Type: SAE J1703 or FMVSS116 DOT-3
or DOT-4

Replacement Part

Caution

- Brake fluid will damage painted surfaces. Be careful not to spill any on painted surfaces. In addition, if there is any brake fluid on the wiring harness, the wire insulation may corrode causing a malfunction such as a short circuit. If brake fluid gets on a painted surface or wiring harness, wash and flush it off completely with water immediately.

1. Remove the wheel and tire. (See WHEEL AND TIRE REMOVAL/INSTALLATION.)
2. Remove in the order indicated in the table.
3. Install in the reverse order of removal.
4. After installation, add brake fluid, bleed the air, and inspect for fluid leakage. (See BRAKE FLUID AIR BLEEDING.)
5. Depress the brake pedal a few times, rotate the wheel by hand, and verify that the brake does not drag.

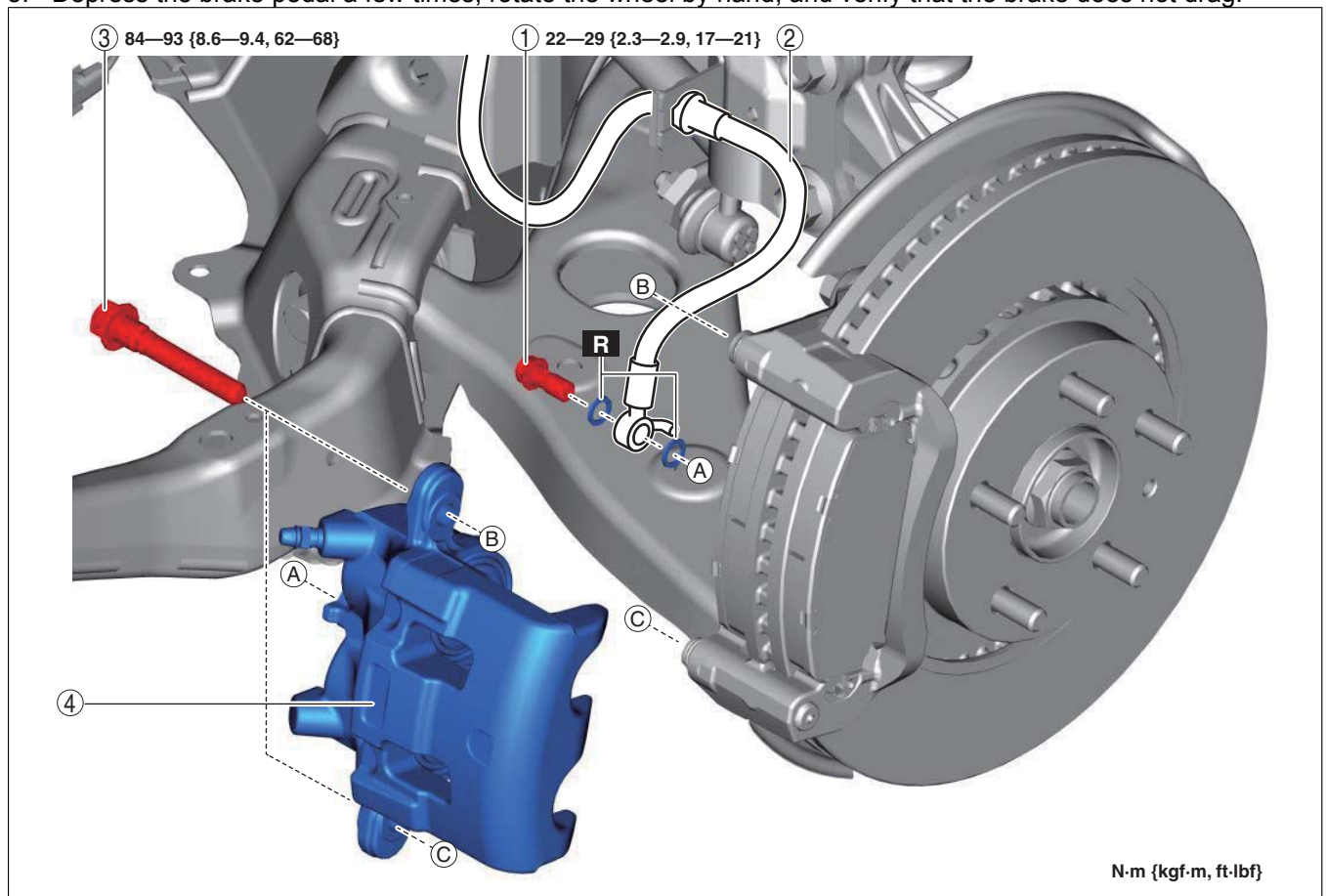

ac5wzw00009649

1	Bolt
2	Brake hose
3	Bolt

4	Front brake caliper (See Front Brake Caliper Installation Note.)
---	---

Front Brake Caliper Installation Note

Caution

- Before installing the caliper, verify that the dust seal does not protrude from the piston surface. Otherwise, the dust seal may be damaged and the braking performance could worsen.

- Do not use a sharp-tipped tool when inserting the dust seal. Otherwise, the dust seal may be damaged.

1. Clean the exposed area of the piston.
2. Push the piston in using the commercially available disc brake expand tool.

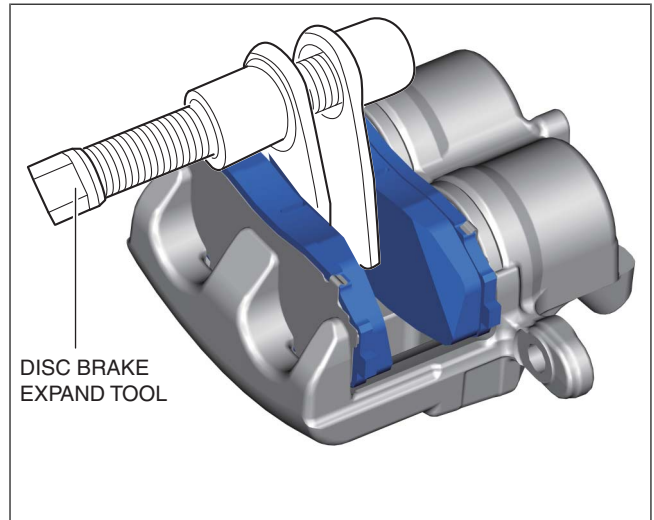

ac5wzw00009650

3. Verify that the dust seal installation position is lower than the piston surface as shown in the figure.

GOOD



DUST SEAL

PISTON SURFACE



NO GOOD



DUST SEAL

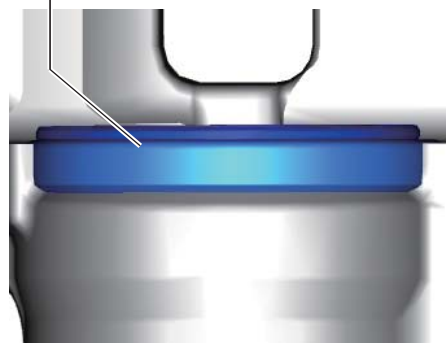

ac8wzw00003250

- If the dust seal protrudes from the piston surface, install the SST as shown in the figure and press the dust seal back to the correct position.

4. Install the front brake caliper component.

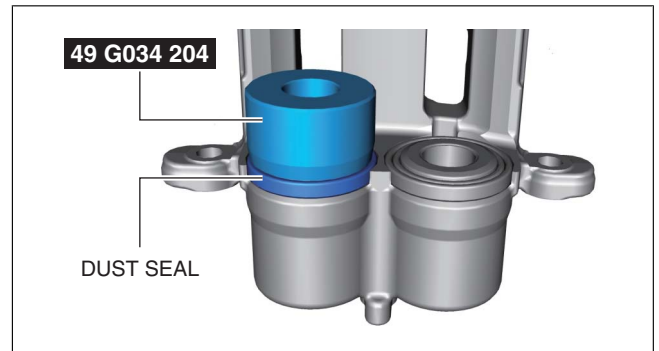

ac8wzw00003251