

■ A-PILLAR TRIM REMOVAL/INSTALLATION

id091700801900

id091700801900

Replacement part

Clip (with grommet)

Quantity: 1

Location of use: A-pillar trim

Removal

1. Disconnect the negative battery terminal. (With tweeter) (See NEGATIVE BATTERY TERMINAL DISCONNECTION/CONNECTION.)

2. Partially peel back the seaming welt.

ILLUSTRATION INDICATES LEFT SIDE.
(RH SIDE IDENTICAL)

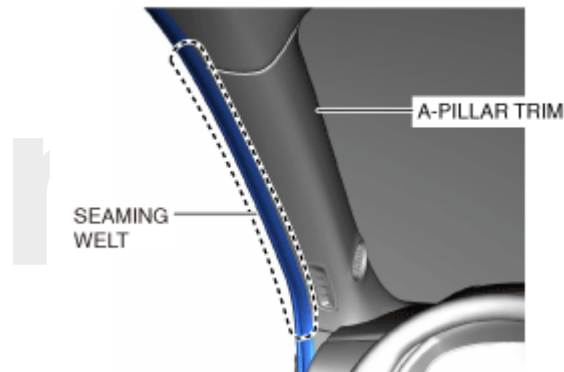

ac5uuw00007552

3. Hold the shaded areas of the A-pillar trim shown in the figure, pull it in the direction of the arrow, and then detach clips A and B.

ILLUSTRATION INDICATES LEFT SIDE. (RH SIDE IDENTICAL)

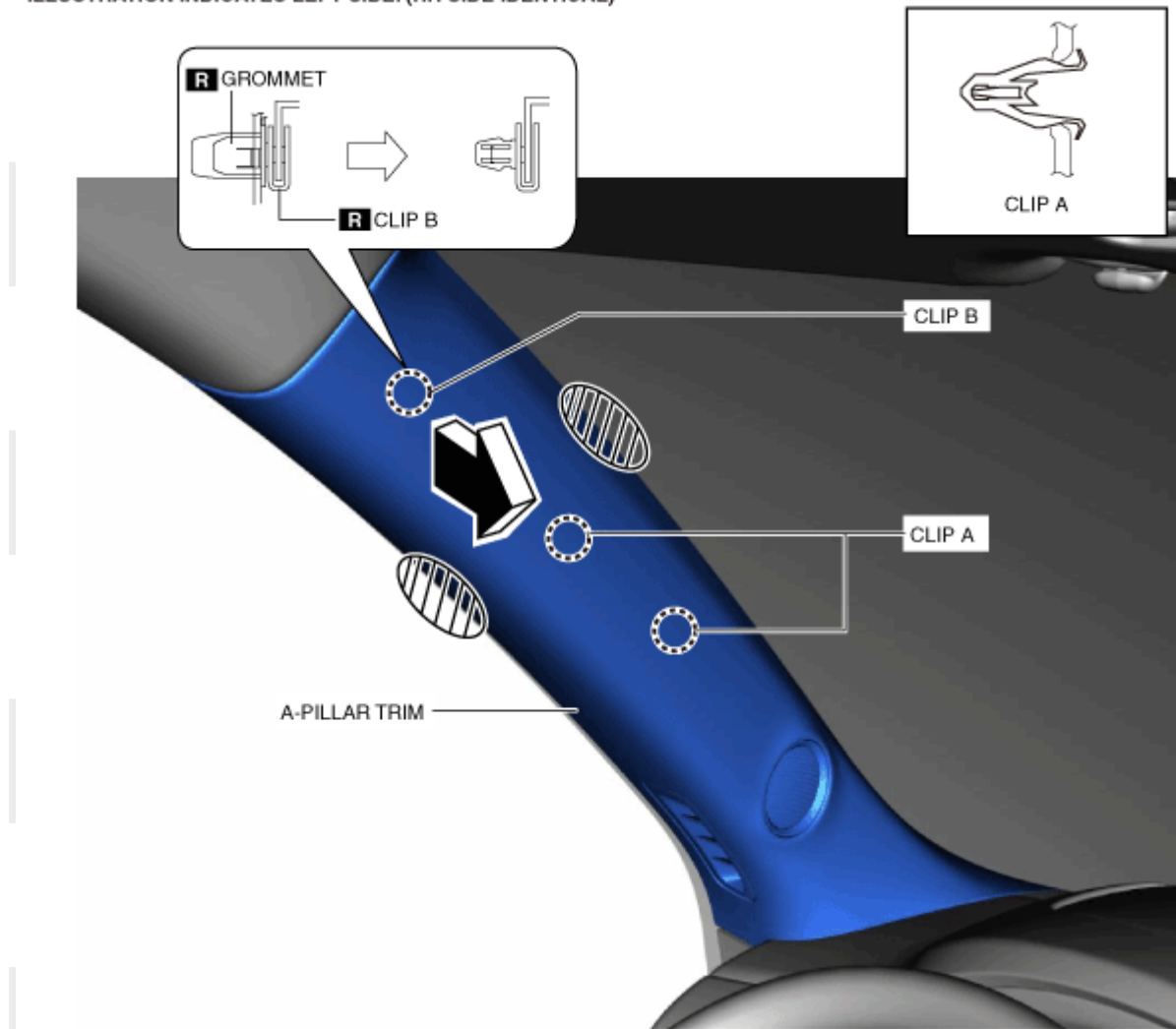

ac5uuw00005288

4. Cut the lead wire connecting clip B and the grommet using a nipper.

ILLUSTRATION INDICATES LEFT SIDE. (RH SIDE IDENTICAL)

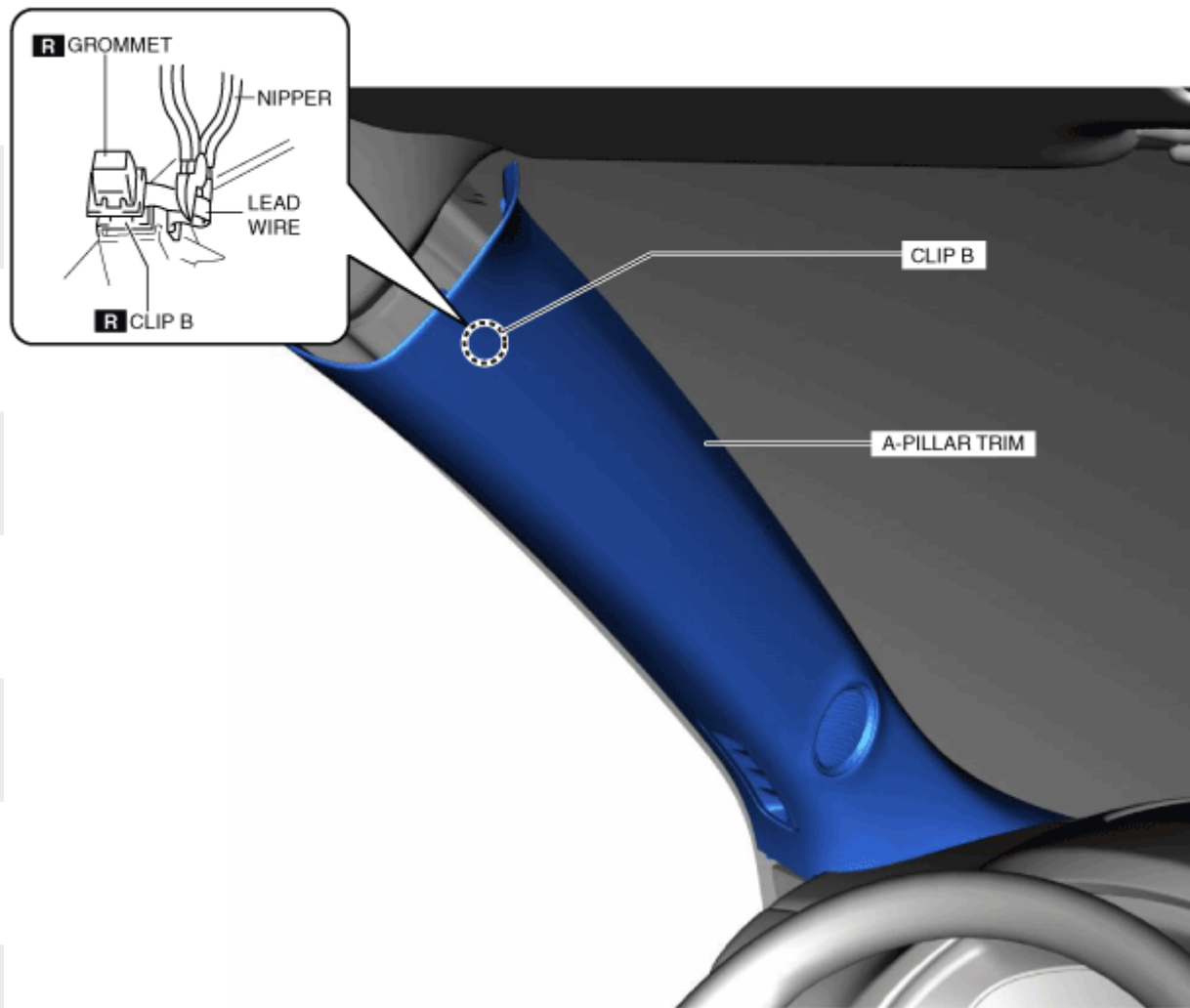

ac5uuw00005289

5. Pull the A-pillar trim in the direction of the arrow shown in the figure and remove it while detaching guides A and B.

ILLUSTRATION INDICATES LEFT SIDE. (RH SIDE IDENTICAL)

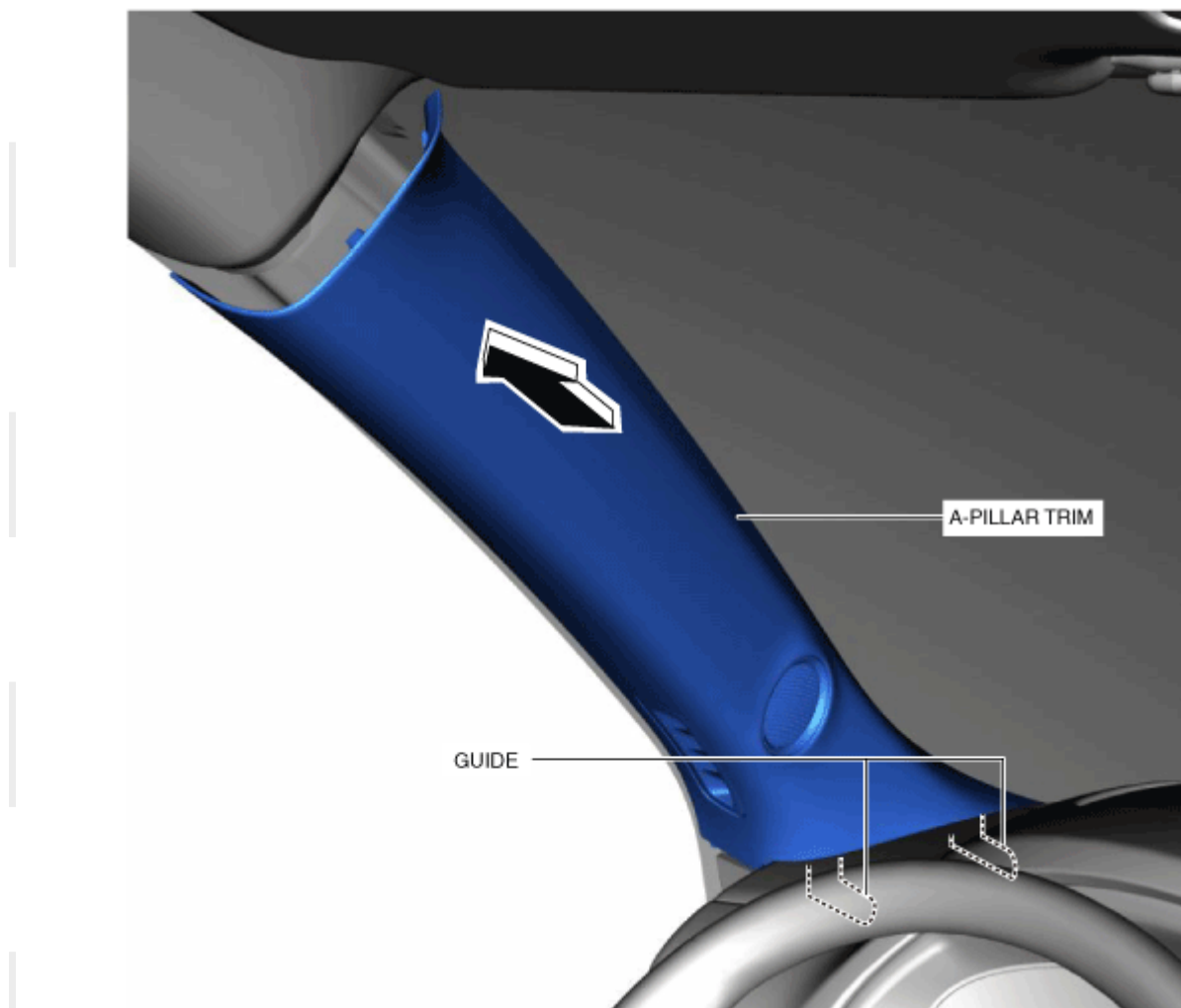

ac5uuw00005290

6. Disconnect the tweeter connector (With tweeter)

7. Remove the tweeter and the tweeter grille as a single unit. (With tweeter)

mazDa
mazDa

ILLUSTRATION INDICATES LEFT SIDE.
(RH SIDE IDENTICAL)

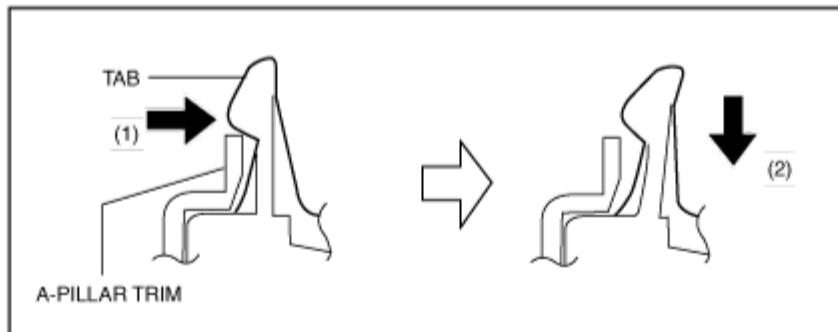
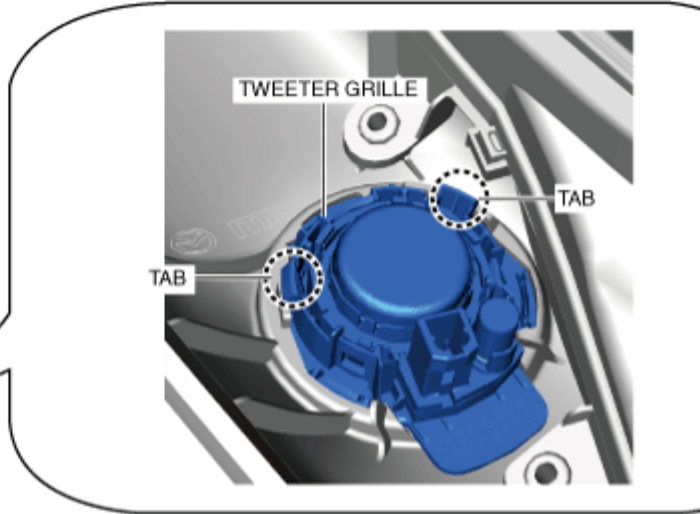
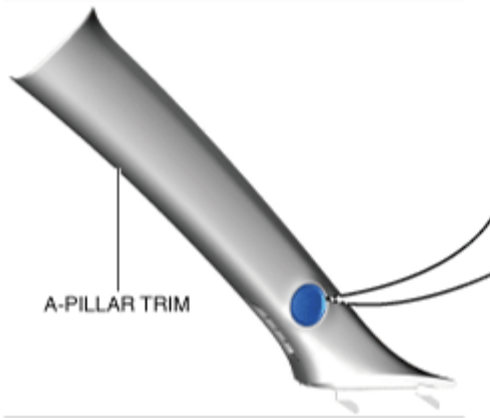

ac5wzw00011718

8. Insert a tape-wrapped flathead screwdriver into the position shown in the figure, move it in the direction of the arrow, and then detach the hook.

mazDa
mazDa
mazDa

ILLUSTRATION INDICATES LEFT SIDE. (RH SIDE IDENTICAL)

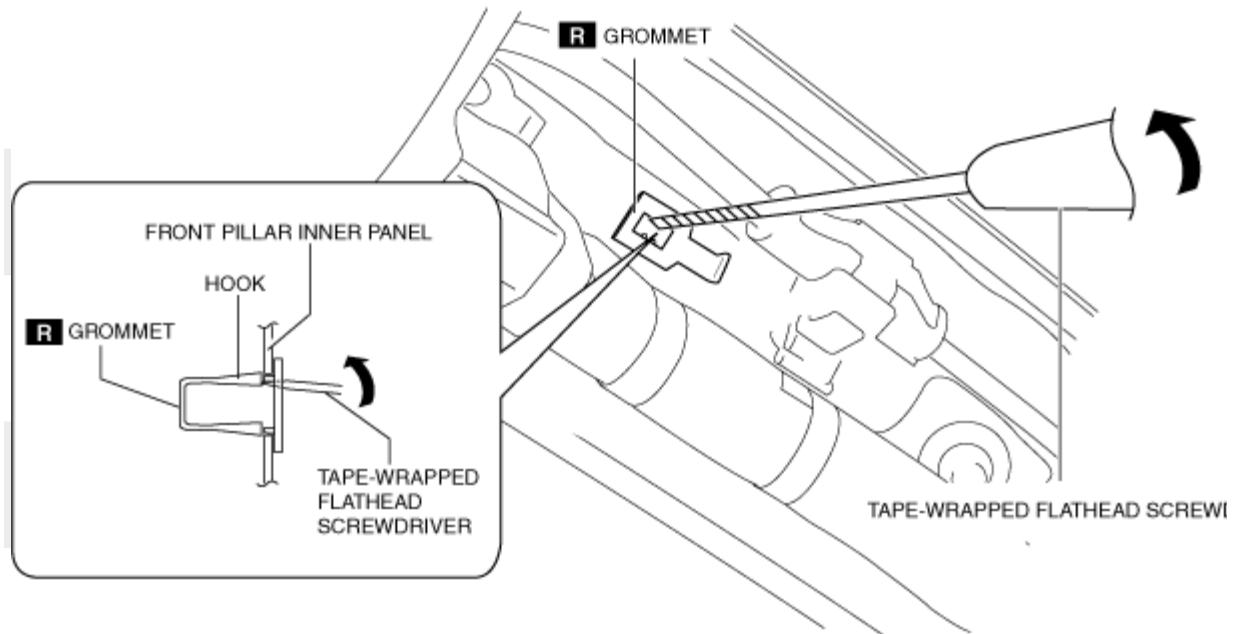

ac5uuw00005291

9. Insert the tape-wrapped flathead screwdriver into the position shown in the figure, and while moving it in the direction of arrow (1) to detach the hook, pull the grommet in the direction of arrow (2) and remove it from the front pillar inner panel.

ILLUSTRATION INDICATES LEFT SIDE. (RH SIDE IDENTICAL)

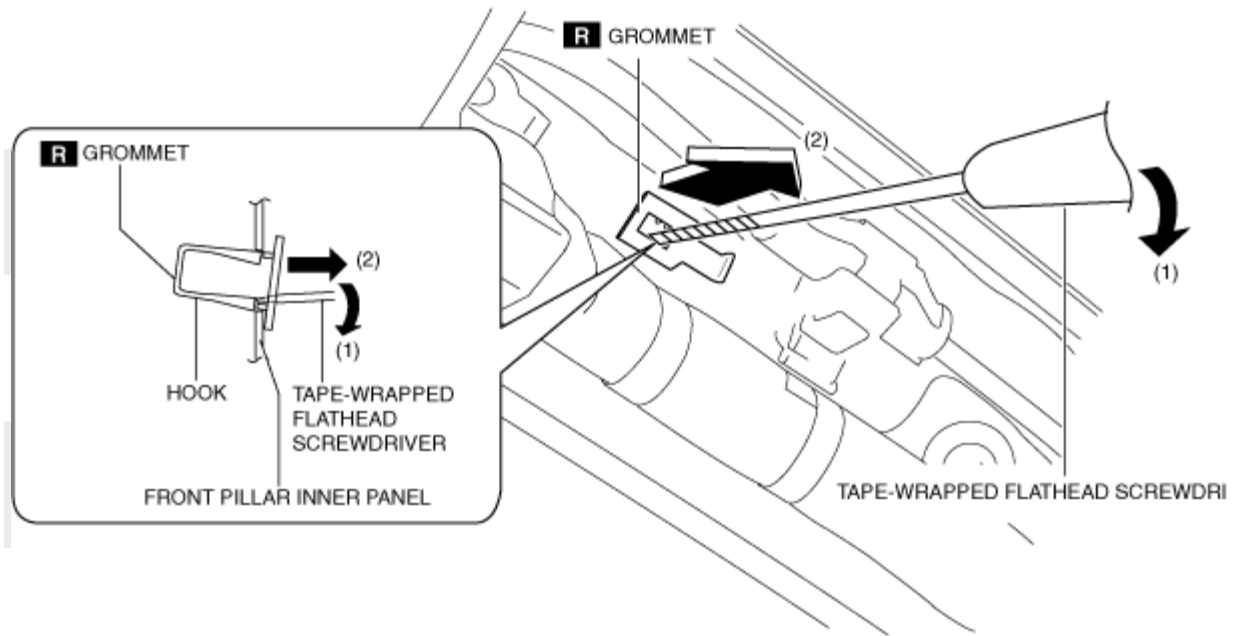

ac5uuw00005292

mazDa

Installation

1. Install the new clip B and grommet to the A-pillar trim.
2. Insert guide A into the dashboard hole.

mazDa

mazDa

mazDa

ILLUSTRATION INDICATES LEFT SIDE. (RH SIDE IDENTICAL)

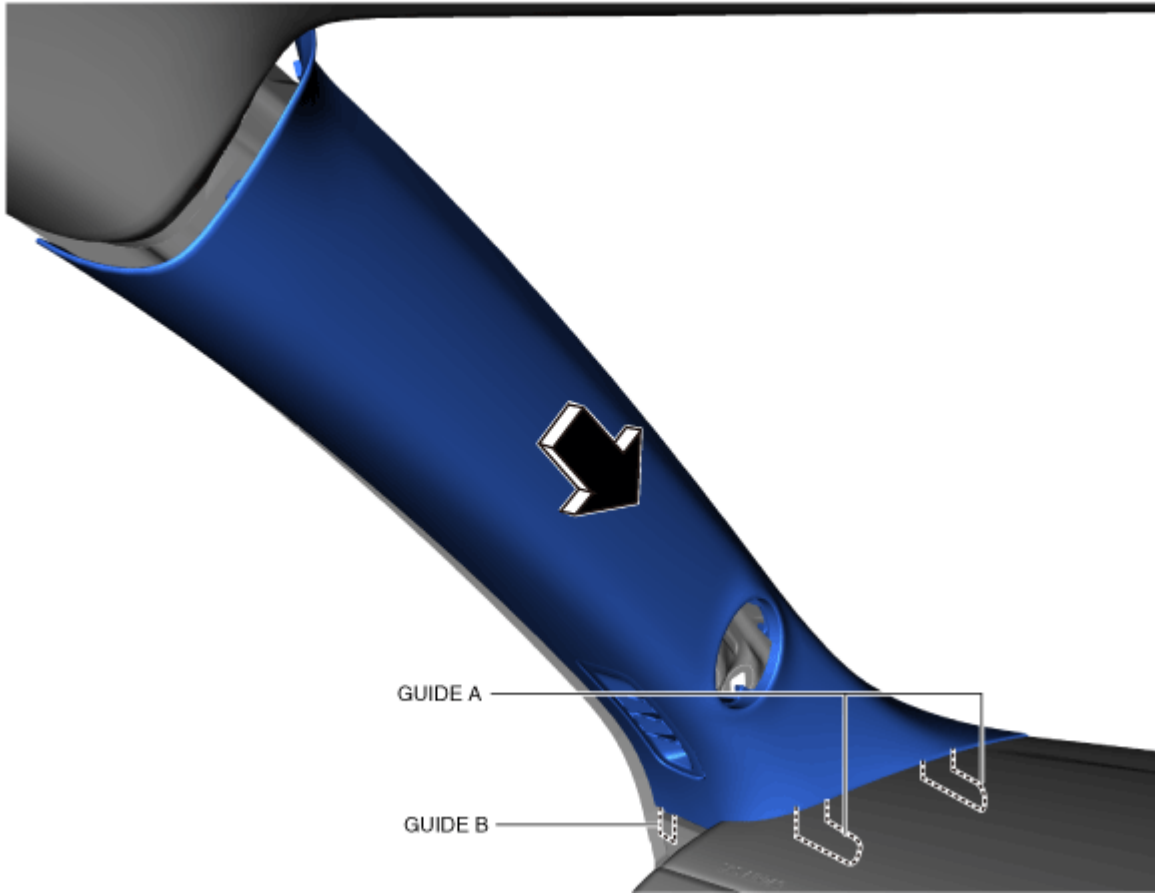

ac5wzw00011719

3. Insert guide B into the position on the dashboard shown in the figure.

4. Pull out the tweeter connector from the tweeter installation hole. (With tweeter)

ILLUSTRATION INDICATES LEFT SIDE. (RH SIDE IDENTICAL)

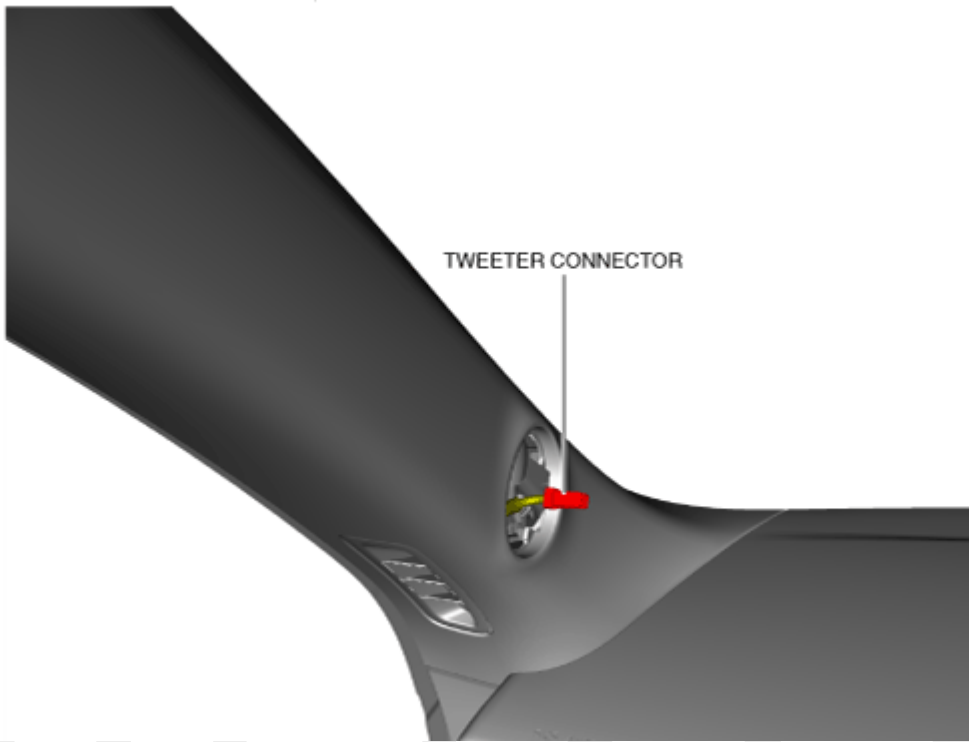

ac5wzw00011720

5. Install clips A and clip B in the order shown in the figure.

ILLUSTRATION INDICATES LEFT SIDE. (RH SIDE IDENTICAL)

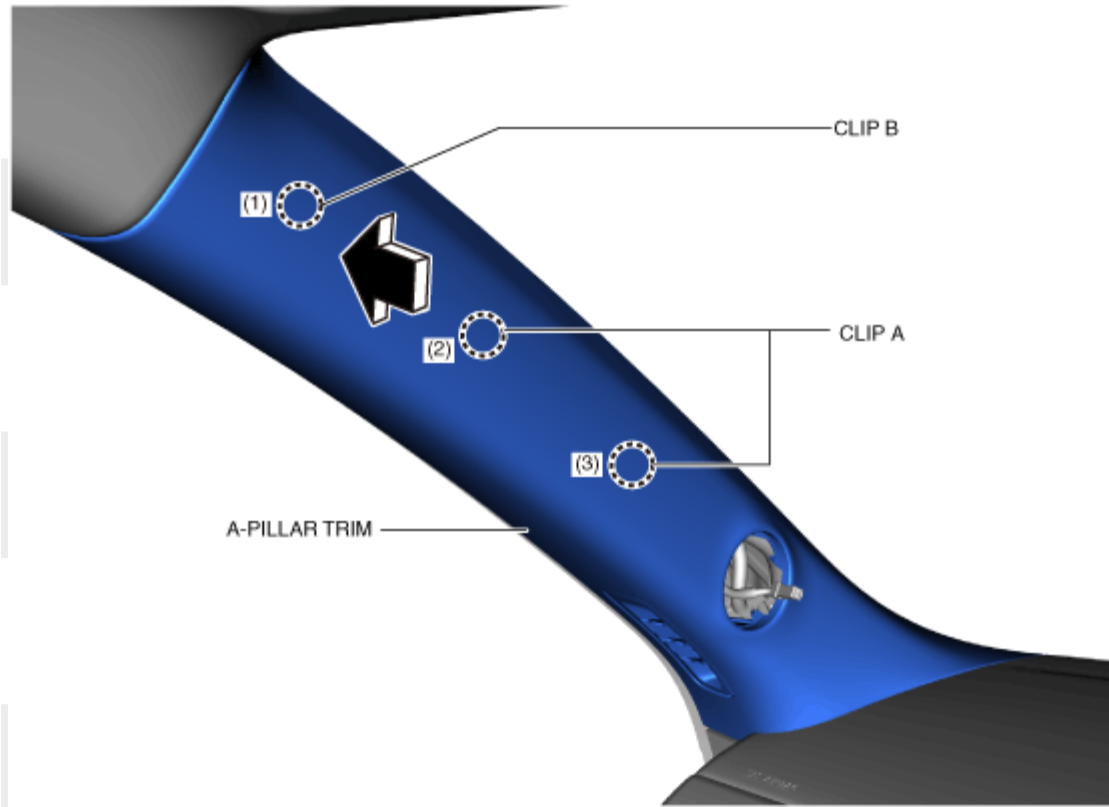

ac5wzw00011721

6. Connect the tweeter connector. (With tweeter)

ILLUSTRATION INDICATES LEFT SIDE. (RH SIDE IDENTICAL)

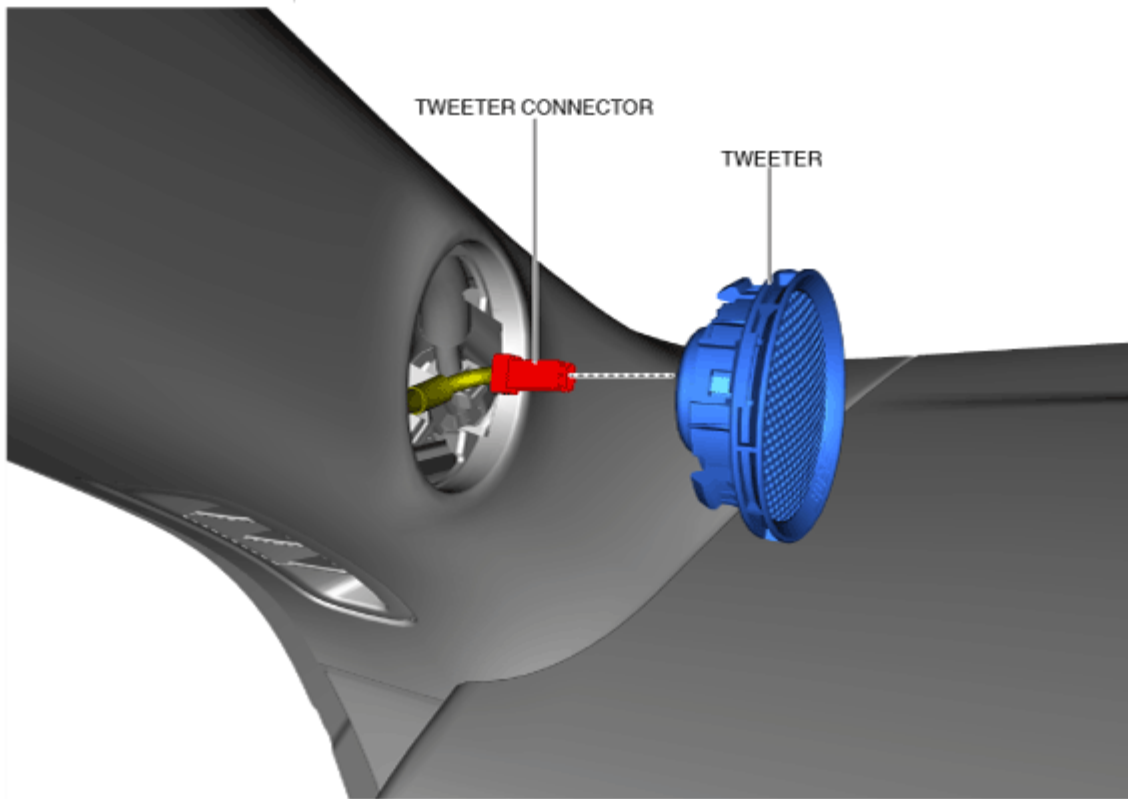

ac5wzw00011722

7. Move the tweeter in the order of arrows (1) and (2) shown in the figure and install it. (With tweeter)

ILLUSTRATION INDICATES LEFT SIDE. (RH SIDE IDENTICAL)

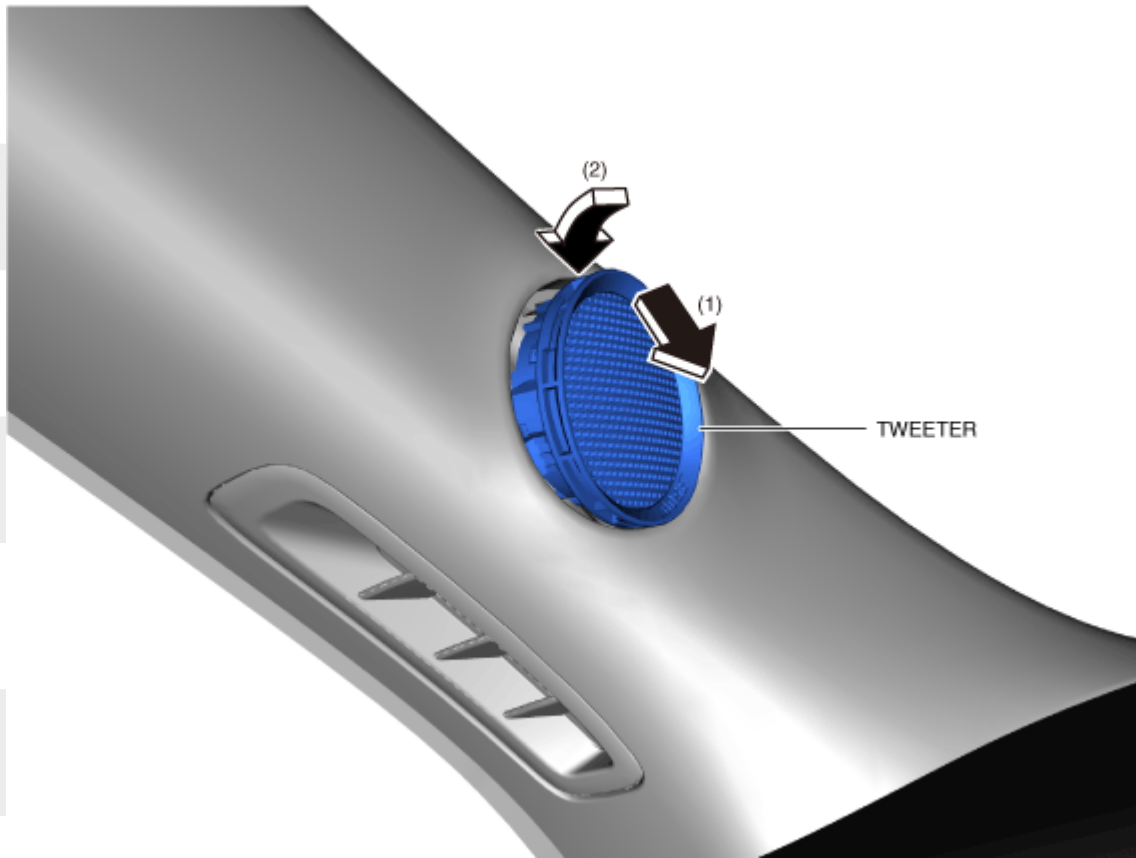

ac5wzw00011723

8. Install the seaming welt.

ILLUSTRATION INDICATES LEFT SIDE.
(RH SIDE IDENTICAL)

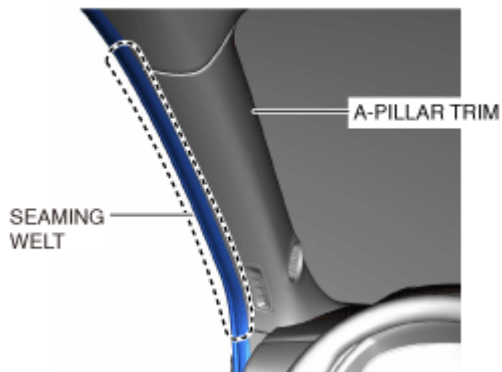

ac5uuw00007552

9.Connect the negative battery terminal. (With tweeter) (See NEGATIVE BATTERY TERMINAL DISCONNECTION/CONNECTION.)

mazDa

mazDa

mazDa

mazDa

mazDa

mazDa